

High Performance gas radiant tube

## SolarHP L

23, 36, 50



SOLARONICS Chauffage SA. 78 rue du Kemmel – CS20302 – 59429 ARMENTIERES CEDEX France

Tél : +3 (0)3.20.10.59.59 - Fax : +33 (0)3.20.35.57.22

Site : [www.solaronics.com](http://www.solaronics.com)

TECHNICAL INSTRUCTIONS GAS RADIANT TUBE SOLARHP L – NT15004E-GB – 10/11/2016

<b>1. Introduction</b>	<b>4</b>
1.1. General	4
1.1.1. Manufacturer's liability	4
1.1.2. Installer's liability	4
1.1.3. User's liability	5
1.2. Certifications	5
<b>2. Safety instructions and recommendations</b>	<b>6</b>
2.1. Safety instructions	6
2.2. Recommendations	6
<b>3. Description</b>	<b>8</b>
3.1. Main components	9
3.2. Burner housing	10
3.3. Operating cycle	12
<b>4. Technical specifications</b>	<b>13</b>
<b>5. Overall and interface dimensions</b>	<b>14</b>
5.1. Appliances	14
5.2. Flue assembly	15
5.2.1. Tilted appliance	15
5.2.2. B22 (roof)	15
<b>6. Appliance installation</b>	<b>16</b>
6.1. General rules	18
6.2. Assembly	19
6.2.1. Necessary tooling	19
6.2.2. Operations	19
6.3. Implantation	24
6.3.1. Recommended hanging heights	25
6.3.2. Tilt	25
6.3.3. Handling for hanging	26
6.3.4. Hanging	26
6.4. Flue connection	27
6.4.1. A type	27
6.4.2. B type flue connexion	28
6.5. Gas connection	28
<b>7. Temperature control - electrical connection</b>	<b>30</b>
7.1. Temperature control	30
7.2. Electrical connections	30
7.2.1. Connections	30
7.2.2. Electrical drawing	33
<b>8. Commissioning</b>	<b>35</b>
8.1. Start-up	35
8.2. Burner setting	36
<b>9. Troubleshooting</b>	<b>38</b>
9.1. Troubleshooting	38
9.2. Spare parts	40
<b>10. Maintenance</b>	<b>40</b>



SOLARONICS Chauffage SA. 78 rue du Kimmel – CS20302 – 59429 ARMENTIERES CEDEX France

Tél : +3 (0)3.20.10.59.59 - Fax : +33 (0)3.20.35.57.22

Site : [www.solaronics.com](http://www.solaronics.com)

TECHNICAL INSTRUCTIONS GAS RADIANT TUBE SOLARHP L – NT15004E-GB – 10/11/2016

<b>11. Warranty</b> .....	<b>42</b>
<b>12. Information</b> .....	<b>43</b>
<b>APPENDIX</b> .....	<b>55</b>
End of life of equipment .....	55
The right thing for the safety .....	55
Smell gas? Good reactions!.....	55



SOLARONICS Chauffage SA. 78 rue du Kemmel – CS20302 – 59429 ARMENTIERES CEDEX France

Tél : +3 (0)3.20.10.59.59 - Fax : +33 (0)3.20.35.57.22

Site : [www.solaronics.com](http://www.solaronics.com)

TECHNICAL INSTRUCTIONS GAS RADIANT TUBE SOLARHP L – NT15004E-GB – 10/11/2016

# 1. Introduction

---

In this manual, the warnings are used to point to specific information. We want to ensure the user safety, to avoid any problem and to ensure proper operation of the appliance.



## **WARNING**

Indicates a potential hazard which can cause bodily injuries and/or material damage



Indicates important information.



Indicates a reference to other notices or other pages of the manual.



Before installation and commissioning the device, read carefully all enclosed notices.

## 1.1. General

---

### 1.1.1. Manufacturer's liability

---

Our products are manufactured in compliance with various applicable European directives requirements. They are thus supplied with EC markings and all necessary documents. With our commitment to quality products, we constantly seek to improve them. We therefore reserve the right at any time to modify the characteristics stated in this document.

Our liability as a manufacturer does not apply in the following cases:

- Failure to follow operating instructions for the appliance.
- Failure to maintain or insufficiently maintain the appliance.
- Failure to follow installation instructions for the appliance.

### 1.1.2. Installer's liability

---

The installer is responsible for installation and first commissioning of the device. The installer must observe the following:

- Read and follow the instructions given in the instruction manuals provided with the device.
- Carry out installation in accordance with the applicable legislation and standards.
- Carry out the first commissioning and carry out all necessary controls.
- Explain the installation to the user.
- Inform the user that he cannot make changes in the appliance's design and to the installation by himself. The slightest modification



SOLARONICS Chauffage SA. 78 rue du Kimmel – CS20302 – 59429 ARMENTIERES CEDEX France

Tél : +3 (0)3.20.10.59.59 - Fax : +33 (0)3.20.35.57.22

Site : [www.solaronics.com](http://www.solaronics.com)

TECHNICAL INSTRUCTIONS GAS RADIANT TUBE SOLARHP L – NT15004E-GB – 10/11/2016

(change, removal...) of security components or parts automatically results in the appliance's CE marking becoming invalid.

- Alert the user about the obligation to control and maintain the device.
- Hand all documents to the user.

### 1.1.3. User's liability

---

To ensure correct operation of the appliance, the user must observe the following:

- Read and follow the instructions given in the instructions manuals provided with the device.
- Call in a qualified technician to carry out the installation and perform the initial commissioning.
- Obtain explanations about the installation by Installer.
- Carry out checks and required maintenance.
- Keep all documents in good condition and near the appliance.

## 1.2. Certifications

---

Appliance	Radiant tube
Directive	2009/142/CEE «Gas appliance»
NOx class	3 (NF EN 416-1)
Category	II2Er3P
Flue type	Ambient : A2
	Flue : B22



SOLARONICS Chauffage SA. 78 rue du Kemmel – CS20302 – 59429 ARMENTIERES CEDEX France

Tél : +3 (0)3.20.10.59.59 - Fax : +33 (0)3.20.35.57.22

Site : [www.solaronics.com](http://www.solaronics.com)

TECHNICAL INSTRUCTIONS GAS RADIANT TUBE SOLARHP L – NT15004E-GB – 10/11/2016

## 2. Safety instructions and recommendations

### 2.1. Safety instructions



#### WARNING

The radiant tube is an electrical appliance and must be grounded during installation.

- It is not allowed to obstruct and/or reduce the space reserved for the room or the appliance vents
- Do not obstruct flue exhaust or fresh air suction ducts,
- Do not make any change in the settings made by the qualified technician
- Do not spray water on the heater, or touch this appliance with wet body parts or bare feet,
- Do not touch the hot parts of the heating appliance, and/or moving parts,
- Do not place or hang anything on the device,
- Any work on the appliance is prohibited before it is unplugging it from the mains and cutting the gas supply.
- Do not change the used gas type, security systems or control settings, as this could lead to dangerous situations.
- Call a qualified technician in the case of gas replacement, change of gas pressure or modification of power supply.
- If the appliance doesn't operate for a long period, disconnect the power supply of the appliance. When commissioning, it is advisable to use the service of a professional technician.

Generally, all repair or maintenance works must be carried out exclusively by authorised and qualified personal.



Subscribing to a maintenance agreement is strongly recommended

### 2.2. Recommendations

SolarHP range High Performance radiant tubes are engineered for heating industrial and tertiary premises.

These appliances differ from traditional radiant tubes thanks to the optimisation of their performance:

- Combustion efficiency
- Radiant efficiency
- Seasonal efficiency
- Low noise

Greatest care shall thus be taken during their assembly, installation and setting.



Commissioning should be handed over to SOLARONICS CHAUFFAGE.

The appliances shall be overhauled every year, in order to guarantee their availability, their high performance level and also their safe functioning.



#### WARNING

Only qualified professionals are authorised to modify and install the appliance.

This information forms an integral part of the appliance and must always be kept always with the appliance, even in the event of transfer to another owner or user.

Do not remove or cover the labels and material safety data plates fixed to the devices. Labels and material safety data plates must be readable throughout the device life.



SOLARONICS Chauffage SA. 78 rue du Kimmel – CS20302 – 59429 ARMENTIERES CEDEX France

Tél : +3 (0)3.20.10.59.59 - Fax : +33 (0)3.20.35.57.22

Site : [www.solaronics.com](http://www.solaronics.com)

TECHNICAL INSTRUCTIONS GAS RADIANT TUBE SOLARHP L – NT15004E-GB – 10/11/2016

Install the device in a sufficiently ventilated room.

Please contact us for any other application other than those described in this document

**DON'Ts:**

Do not install radiant tube appliances:

- Outside
- In environments with explosive risks,
- Premises containing corrosive products in the ambient air
- In extremely wet premises (electrical shock hazard).



SOLARONICS Chauffage SA. 78 rue du Kimmel – CS20302 – 59429 ARMENTIERES CEDEX France

Tél : +3 (0)3.20.10.59.59 - Fax : +33 (0)3.20.35.57.22

Site : [www.solaronics.com](http://www.solaronics.com)

TECHNICAL INSTRUCTIONS GAS RADIANT TUBE SOLARHP L – NT15004E-GB – 10/11/2016

### 3. Description

---

Any object at a temperature above absolute zero emits energy in the form of electromagnetic radiation.

These rays travel in a straight line and may be reflected and converted into heat when hitting a solid.

These rays are called infrared wherever temperatures emitted are of the order of a few hundred degrees.

As it does not heat the air, the method is particularly well suited for:

- the heating of large buildings
- the heating of small or poorly insulated buildings,
- buildings where large quantities of air have to be changed,

and for :

- intermittent heating,
- area heating.

The SolarHP High Performance gas radiant tube is a direct overhead heating system, burning natural gas and propane, which complies with the European directive applicable to gas-fired appliances.

The SolarHP High Performance gas radiant tube heater burns gas inside a tube, an extractor fan creates a vacuum inside the tube:

- lengthens the flame produced by the atmospheric burner
- extracts the combustion products.

When heated, the tubes emit infrared rays directed downwards by a reflector.



SOLARONICS Chauffage SA. 78 rue du Kimmel – CS20302 – 59429 ARMENTIERES CEDEX France

Tél : +3 (0)3.20.10.59.59 - Fax : +33 (0)3.20.35.57.22

Site : [www.solaronics.com](http://www.solaronics.com)

TECHNICAL INSTRUCTIONS GAS RADIANT TUBE SOLARHP L – NT15004E-GB – 10/11/2016



### 3.1. Main components

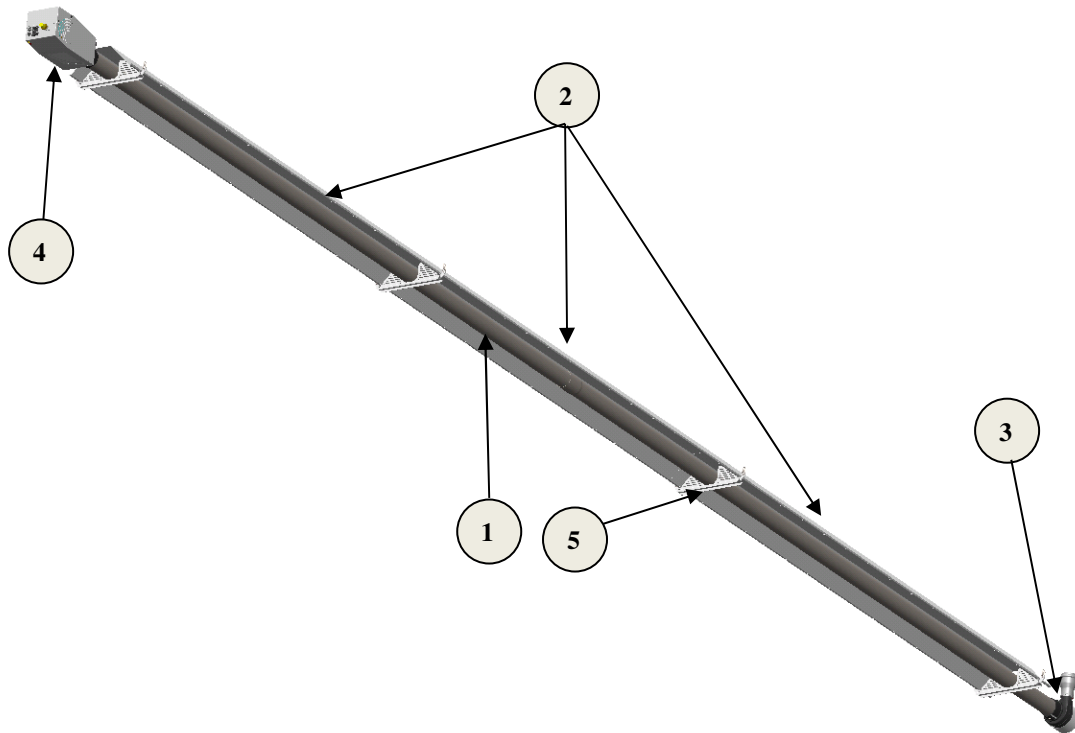

REP	Designation	Quantity	Observations
1	Radiant tubes	2	SolarHP L23, SolarHP L 36
		4	SolarHP L 50
2	Reflectors	3	SolarHP L 23
		5	SolarHP L 36
		7	SolarHP L 50
3	Extractor fan	1	
4	Burner housing	1	
5	Beam	4	SolarHP L 23
		6	SolarHP L 36
		8	SolarHP L 50



SOLARONICS Chauffage SA. 78 rue du Kimmel – CS20302 – 59429 ARMENTIERES CEDEX France

Tél : +3 (0)3.20.10.59.59 - Fax : +33 (0)3.20.35.57.22

Site : [www.solaronics.com](http://www.solaronics.com)

TECHNICAL INSTRUCTIONS GAS RADIANT TUBE SOLARHP L – NT15004E-GB – 10/11/2016

### 3.2. Burner housing

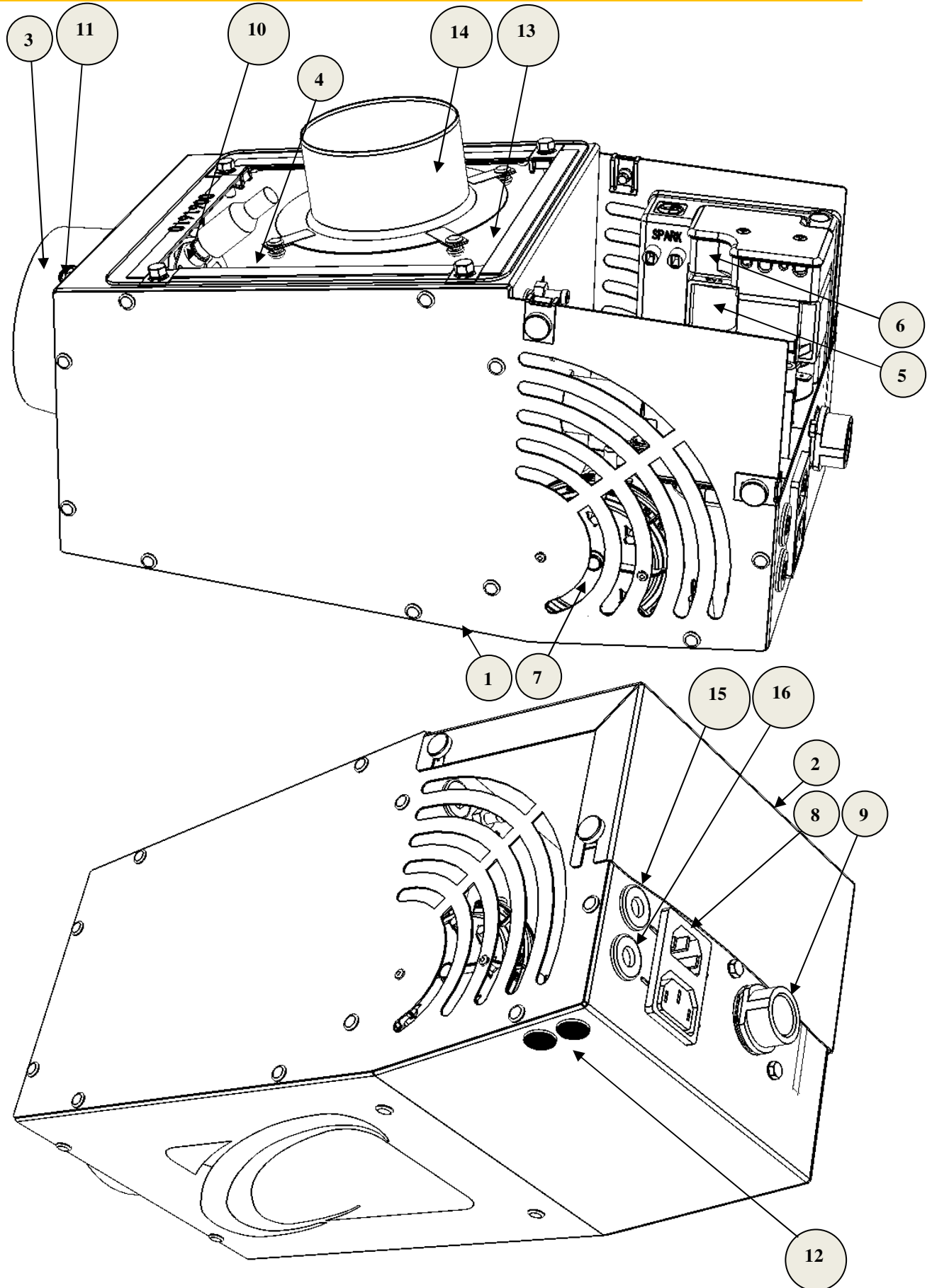

SOLARONICS Chauffage SA. 78 rue du Kemmel – CS20302 – 59429 ARMENTIERES CEDEX France

Tél : +3 (0)3.20.10.59.59 - Fax : +33 (0)3.20.35.57.22

Site : [www.solaronics.com](http://www.solaronics.com)

TECHNICAL INSTRUCTIONS GAS RADIANT TUBE SOLARHP L – NT15004E-GB – 10/11/2016

REP	Designation	Quantity	Observation
1	Housing	1	
2	Access cover	1	Removable without tools Access from above the housing
3	Flange	1	Housing connexion to radiant tube Cast iron (SolarHP L 23, 36) Gasket + screws (SolarHP L 50)
4	Burner	1	Atmospheric
5	Gas valve	1	2 shut-off valves class B + J with a pressure regulator
6	Gas burner control	1	HV sparking. Sparking and safety management
7	Pressure switch	1	Check of combustion air flow
8	Connector	1	Type CEE 22
9	Gas connexion	1	1/2" gas male connexion
10	Electrode	1	Spark and ionisation
11	Allen screw	2	Lock of the flange on the tube (SolarHP L 23, 36)
12	Indicator lights	2	Orange : Voltage presence Red : Lock-out
13	Injector	1	Diameter as per table page 12
14	Air intake	1	Diameter 80 mm : SolarHP L 23 Diameter 100 mm : SolarHP L 36, 50
15	2 <sup>nd</sup> step command cable	2 m	Appliances with option 2 steps
16	In operation signal cable	2 m	Appliances with option "in operation"



SOLARONICS Chauffage SA. 78 rue du Kimmel – CS20302 – 59429 ARMENTIERES CEDEX France

Tél : +3 (0)3.20.10.59.59 - Fax : +33 (0)3.20.35.57.22

Site : [www.solaronics.com](http://www.solaronics.com)

TECHNICAL INSTRUCTIONS GAS RADIANT TUBE SOLARHP L – NT15004E-GB – 10/11/2016

### 3.3. Operating cycle

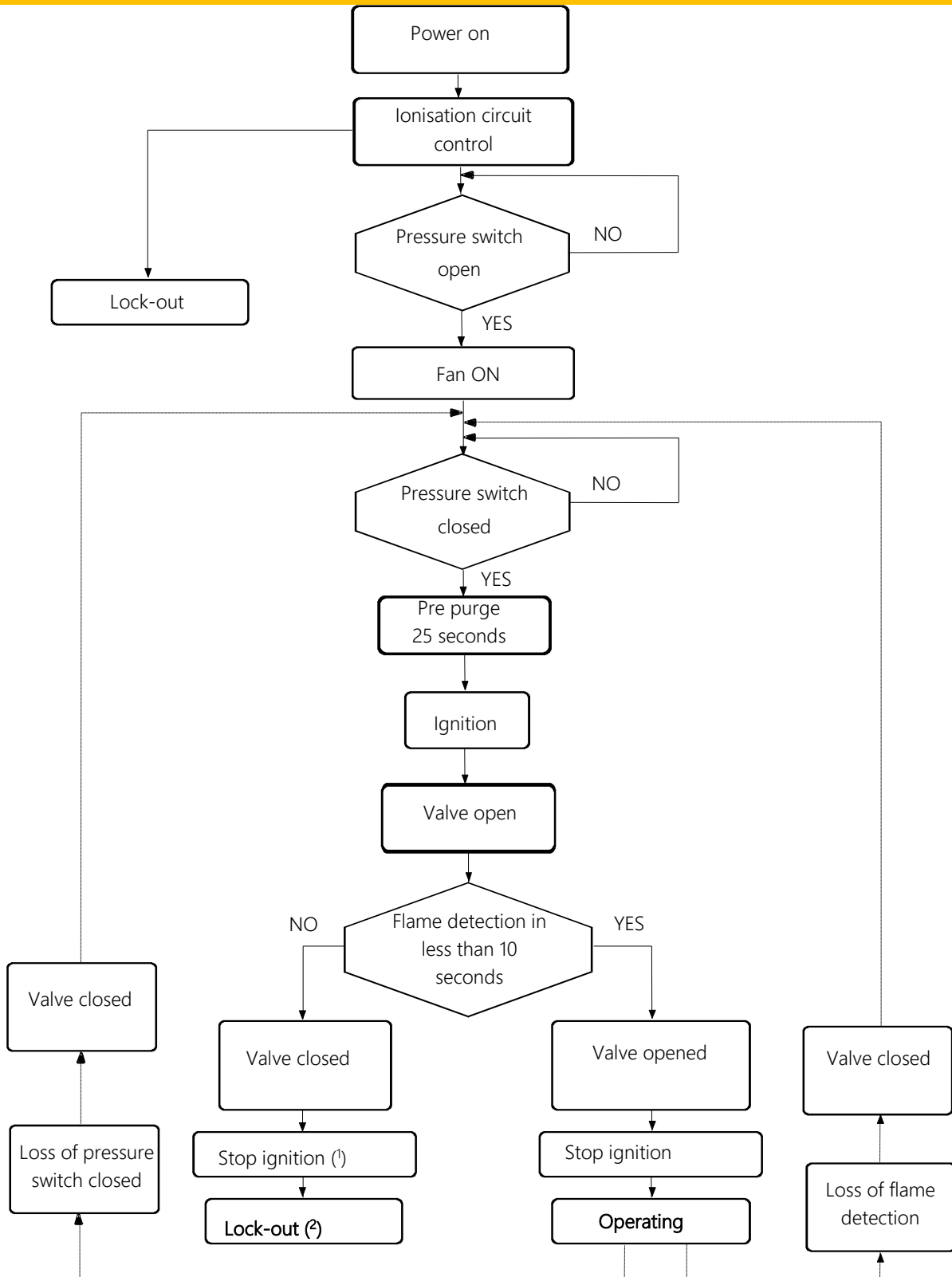

Nota:

- (!) and 25 seconds interpurge before attempts
- (?) after 3 unsuccessful attempts  
Reset by power cut-off and then power on



SOLARONICS Chauffage SA. 78 rue du Kemmel – CS20302 – 59429 ARMENTIERES CEDEX France

Tél : +3 (0)3.20.10.59.59 - Fax : +33 (0)3.20.35.57.22

Site : [www.solaronics.com](http://www.solaronics.com)

TECHNICAL INSTRUCTIONS GAS RADIANT TUBE SOLARHP L – NT15004E-GB – 10/11/2016

## 4. Technical specifications

Model	Unit	SolarHP L 23	SolarHP L 36	SolarHP L 50
Heat input	2 <sup>nd</sup> step kW NCV	20	32	48
Heat input	1 <sup>st</sup> step(*) kW NCV	8	25.5	37
Combustion efficiency	%	90	90	91
Radiant efficiency	%	65	65	65
<b>G 20 (H gas)</b> Normal supply pressure : 20 mbar (17 mbar mini / 25 mbar maxi)				
Volume flow rate 15°C, 1013 mbar	m3/h	2.12	3.39	5.08
Injector diameter	1/100 of mm	380	490	590
<b>G 25 (L gas)</b> Normal supply pressure: 25 mbar (20 mbar mini / 30 mbar maxi)				
Volume flow rate 15°C, 1013 mbar	m3/h	2.46	3.94	5.91
Injector diameter	1/100 de mm	380	490	590
<b>G31 (Propane)</b> Normal supply pressure : 37 mbar (25 mbar mini / 45 mbar maxi)				
Mass flow rate	kg/h	1.56	2.5	3.8
Injector diameter	1/100 de mm	240	310	380
<b>Gas connection</b>	1/2" gas male connexion			
<b>Electrical connection</b>	230V 1N ~ 50Hz + 230V RAC 50Hz (*) CEE22 type connector 2 poles + ground			
Electrical consumption	A	0.25	0.6	1
Number of hanging points		8	12	16
Total weight	kg	65	95	140
Air inlet diameter Flue diameter	mm	80	100	100

(\*) Appliances with option 2 steps



SOLARONICS Chauffage SA. 78 rue du Kimmel – CS20302 – 59429 ARMENTIERES CEDEX France  
Tél : +3 (0)3.20.10.59.59 - Fax : +33 (0)3.20.35.57.22  
Site : [www.solaronics.com](http://www.solaronics.com)

TECHNICAL INSTRUCTIONS GAS RADIANT TUBE SOLARHP L – NT15004E-GB – 10/11/2016

## 5. Overall and interface dimensions

### 5.1. Appliances

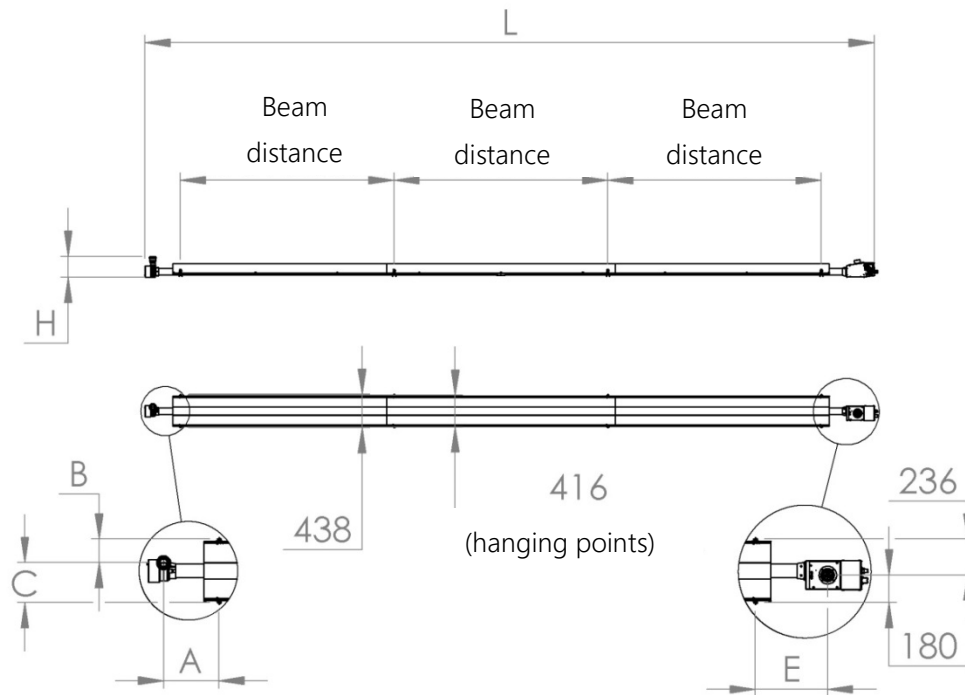

Dimension [mm]	SolarHP L 23	SolarHP L 36	SolarHP L 50
L	9 557	13 999	18 402
H	276	284	366
Width	438		
Hanging points distance	416		
Beam interval	2 800 (x 3)	2 400 (x 5)	2 400 (x 7)
A	363	770	542
B (air inlet > flue)	155	134	106
C	261	282	310
øD	80	100	100
E	475	875	640



SOLARONICS Chauffage SA. 78 rue du Kimmel – CS20302 – 59429 ARMENTIERES CEDEX France

Tél : +3 (0)3.20.10.59.59 - Fax : +33 (0)3.20.35.57.22

Site : [www.solaronics.com](http://www.solaronics.com)

TECHNICAL INSTRUCTIONS GAS RADIANT TUBE SOLARHP L – NT15004E-GB – 10/11/2016

## 5.2. Flue assembly

### 5.2.1. Tilted appliance



Extractor is positioned vertically to ease the flue pipes installation.

### 5.2.2. B22 (roof)

Flue $\varnothing 80$ (SolarHP L 23)	Flue $\varnothing 100$ (SolarHP L 36)	Flue $\varnothing 100$ (SolarHP L 50)
<p>Typical assembly :</p> <ul style="list-style-type: none"> <li>• (1) Flue pipe 1 m</li> <li>• (2) Rain cap</li> </ul>		



#### WARNING

The junctions between pipes must be tight and rigid, make sure all seals are present  
For longest flues install a T 90° and a drain pot at the flue base.



SOLARONICS Chauffage SA. 78 rue du Kimmel – CS20302 – 59429 ARMENTIERES CEDEX France

Tél : +3 (0)3.20.10.59.59 - Fax : +33 (0)3.20.35.57.22







Site : [www.solaronics.com](http://www.solaronics.com)

TECHNICAL INSTRUCTIONS GAS RADIANT TUBE SOLARHP L – NT15004E-GB – 10/11/2016

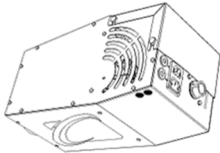
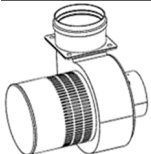
## 6. Appliance installation

**i** Installation of gas appliances must be carried out by qualified personnel, it is determined the premises volume and location characteristics, equipment vent or ventilation device which may be installed on those premises.

Scope of delivery :

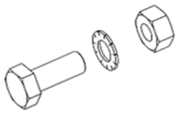
Designation	Quantity	View
Cardboard box	1	
Burner housing	1 (SHP L 50 : including gasket + 4 M8 nut/washer M8 for fixation on tube)	
Extractor fan	1 (SHP L 50 : including gasket + 4 M8x20 screw/washer for fixation on tube)	
Supply cord	1,5 m	
High temperature cable for extractor supply	10 m 15 m 19 m	
Hardware bag	1	
Cable clamp for edge	9 14 18	
Pins	8 12 16	
High temperature glue tube	1	
Fast link ø5	8 12 16	
Self drilling screws 4,8 x 16	3 3 1	
M8x25 bolts for SolarHP L 50 (screw, washer, nut)	12	



SOLARONICS Chauffage SA. 78 rue du Kimmel – CS20302 – 59429 ARMENTIERES CEDEX France

Tél : +3 (0)3.20.10.59.59 - Fax : +33 (0)3.20.35.57.22

Site : [www.solaronics.com](http://www.solaronics.com)

TECHNICAL INSTRUCTIONS GAS RADIANT TUBE SOLARHP L – NT15004E-GB – 10/11/2016

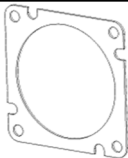
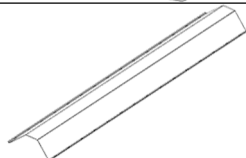
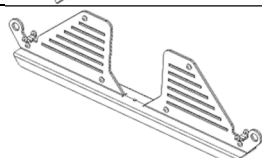
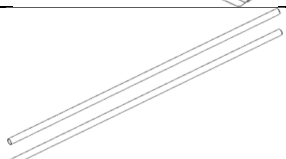

Designation	Quantity	View
Gaskets for SolarHP L 50	2 square + 3 circular Or 5 square	
Reflector	3 5 7	
Beams	4 6 8	
Radiant tubes	1 plain + 1 flare 1 plain + 1 flare 4 with flanges	

#### Reception – Storage

It is essential to check the delivered material status (even if the packaging is intact) and its compliance with the order.

In the event of damage or missing parts, report comments on the carrier's receipt as accurately as possible, the words "subject to unpacking" has no legal value, and then confirm the prejudice by letter within 48h to the carrier. The buyer is responsible to check the goods delivered, no appeal is possible if this procedure is not followed.

Store the material in a clean, dry place, protected from shock, vibration, temperature variations and in a room where humidity is less than 90 %.

#### Handling

Unpack the appliance using protective equipment as required. Handling must be performed by a person equipped with the proper equipment.



SOLARONICS Chauffage SA. 78 rue du Kimmel – CS20302 – 59429 ARMENTIERES CEDEX France

Tél : +3 (0)3.20.10.59.59 - Fax : +33 (0)3.20.35.57.22

Site : [www.solaronics.com](http://www.solaronics.com)

TECHNICAL INSTRUCTIONS GAS RADIANT TUBE SOLARHP L – NT15004E-GB – 10/11/2016

## 6.1. General rules

SolarHP radiant tubes are installed inside the premises. However, this facility is subject to the national security rules depending on the fuel type used and the installation country. If in doubt, check with safety and inspection bodies

### Ventilation:

Premises receiving gas appliances should be provided with permanent ventilation in accordance with the applicable rules in the country of installation.

### Gas connection:

Before installing the appliance, it is necessary to check that the local distribution conditions (gas type, pressure) are compatible with settings of the device to be installed.



### **WARNING**

Minimum distances required for appliance maintenance and safety:

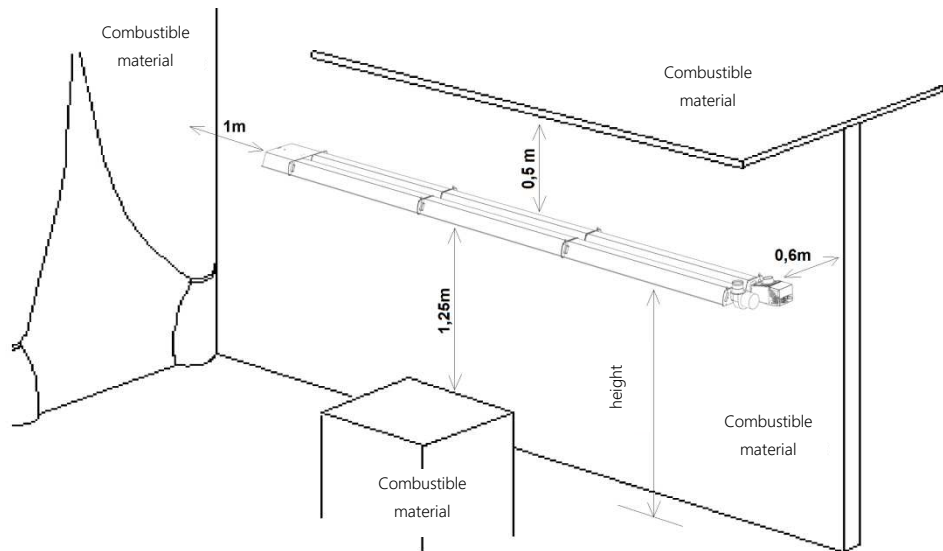

\* Installation height: see §6.3.1.



SOLARONICS Chauffage SA. 78 rue du Kimmel – CS20302 – 59429 ARMENTIERES CEDEX France

Tél : +3 (0)3.20.10.59.59 - Fax : +33 (0)3.20.35.57.22

Site : [www.solaronics.com](http://www.solaronics.com)

TECHNICAL INSTRUCTIONS GAS RADIANT TUBE SOLARHP L – NT15004E-GB – 10/11/2016

## 6.2. Assembly

### 6.2.1. Necessary tooling

6 mm Allen key  
Electric drill with 8 mm and 10 mm tips + extension  
Individual protections: glasses, gloves, shoes, etc

### 6.2.2. Operations

#### ON THE FLOOR:

Put the beams on the floor, with a distance between them of:

- SolarHP L 23 : 2,80 m
- SolarHP L 36 and 50 : 2,40 m

Lay the tubes on the beams

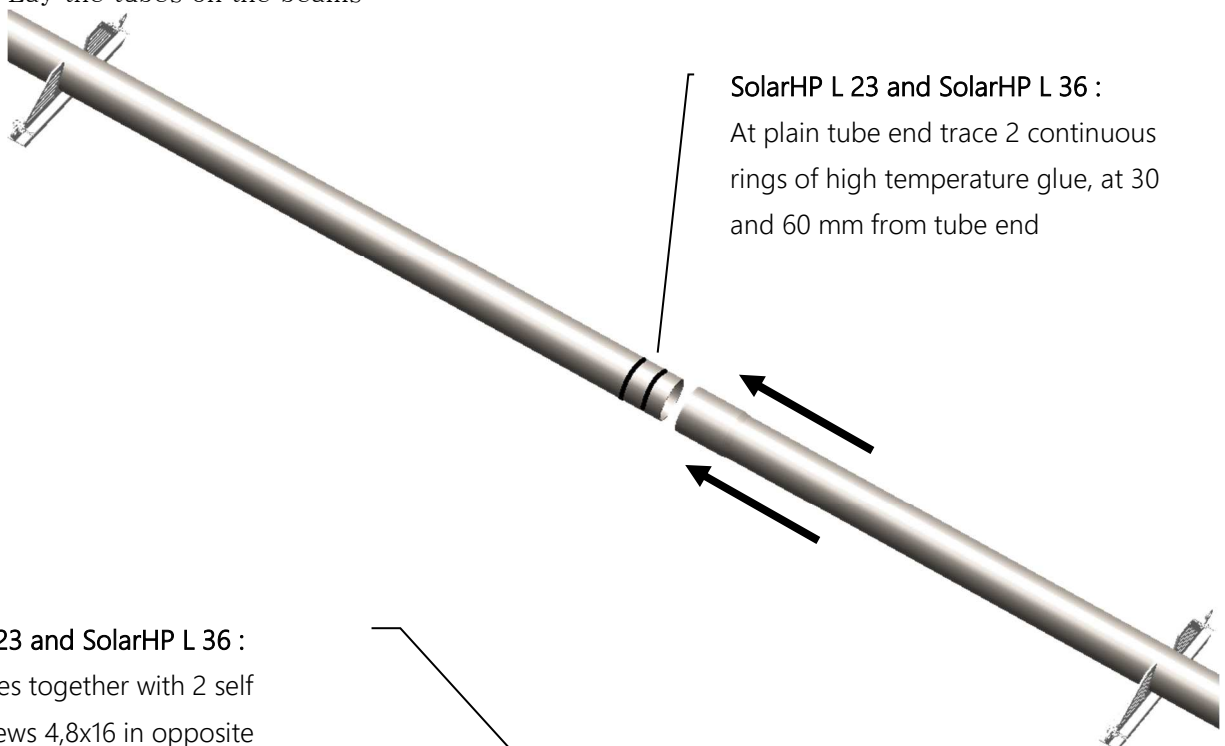

SolarHP L 23 and SolarHP L 36 :  
Fix the tubes together with 2 self  
drilling screws 4,8x16 in opposite  
position, in the middle of the flare

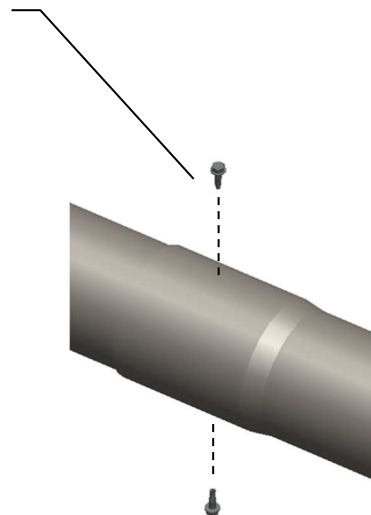

SOLARONICS Chauffage SA. 78 rue du Kemmel – CS20302 – 59429 ARMENTIERES CEDEX France

Tél : +3 (0)3.20.10.59.59 - Fax : +33 (0)3.20.35.57.22

Site : [www.solaronics.com](http://www.solaronics.com)

TECHNICAL INSTRUCTIONS GAS RADIANT TUBE SOLARHP L – NT15004E-GB – 10/11/2016

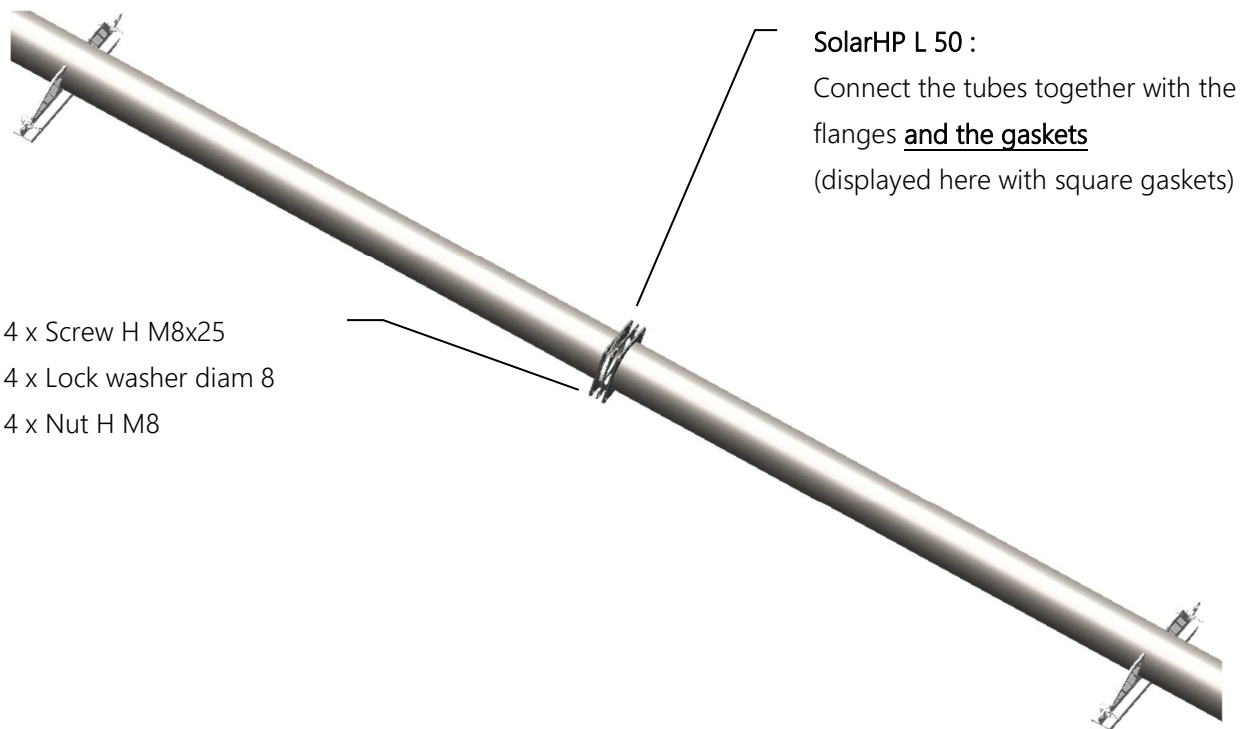

Lay the end reflector, inserting the beam lugs inside the reflector slots

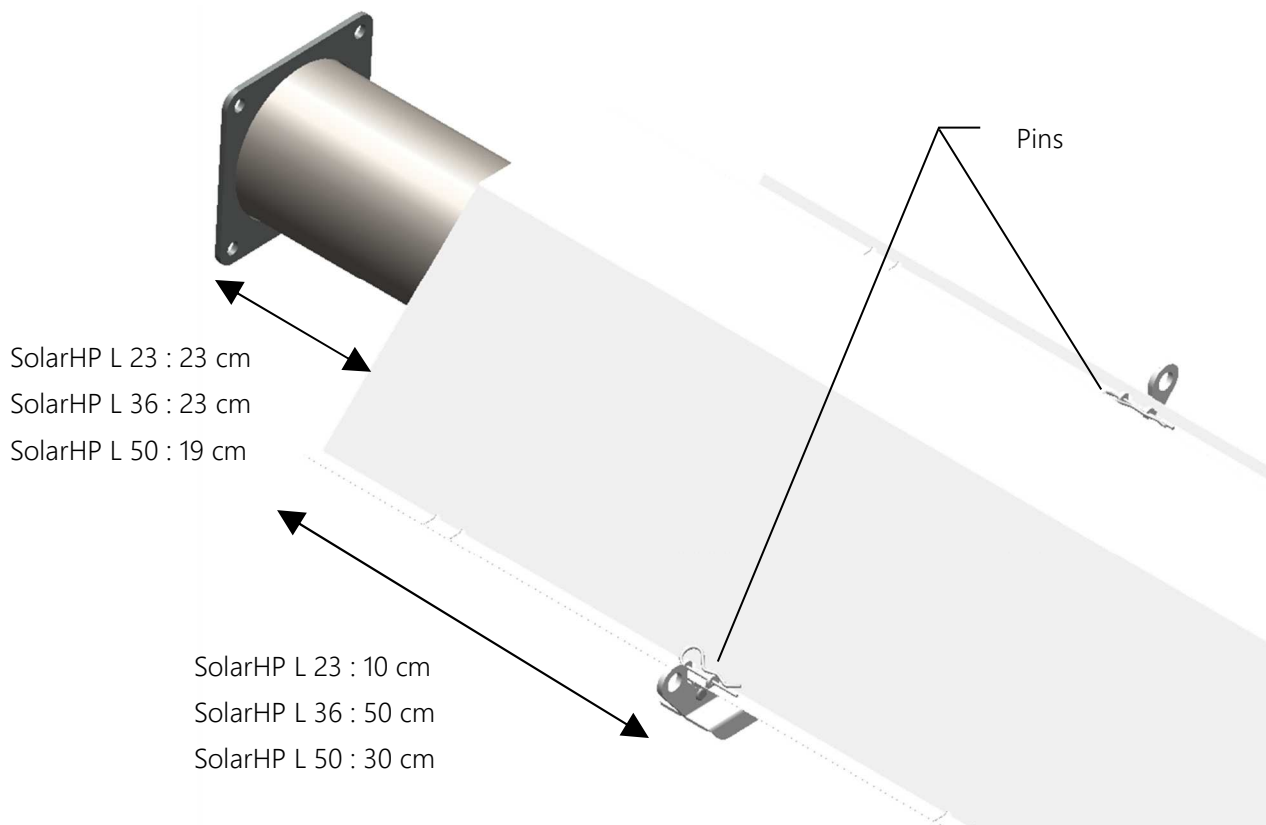

SOLARONICS Chauffage SA. 78 rue du Kemmel – CS20302 – 59429 ARMENTIERES CEDEX France

Tél : +3 (0)3.20.10.59.59 - Fax : +33 (0)3.20.35.57.22

Site : [www.solaronics.com](http://www.solaronics.com)

TECHNICAL INSTRUCTIONS GAS RADIANT TUBE SOLARHP L – NT15004E-GB – 10/11/2016

Lay the following reflectors, overlapping as per following table. Insert the beam lugs inside the reflector slots, and then lock the assembly with the pins.

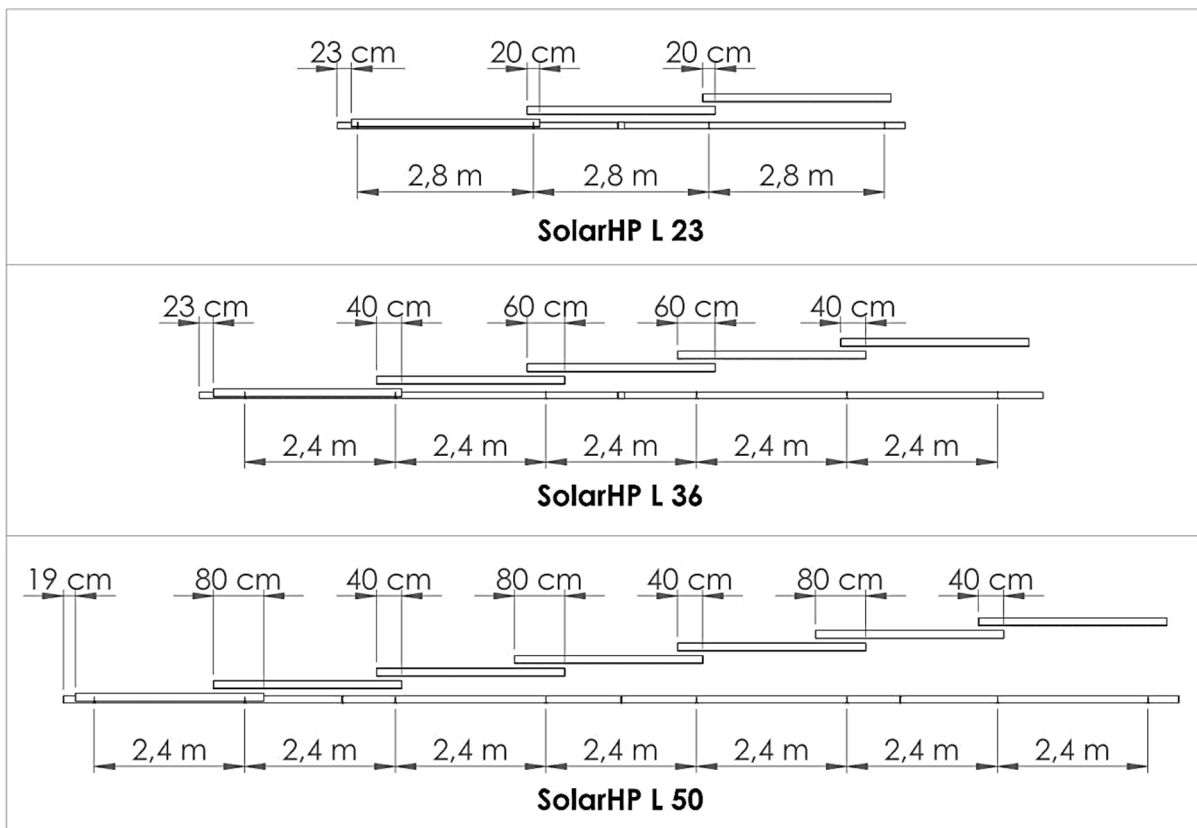
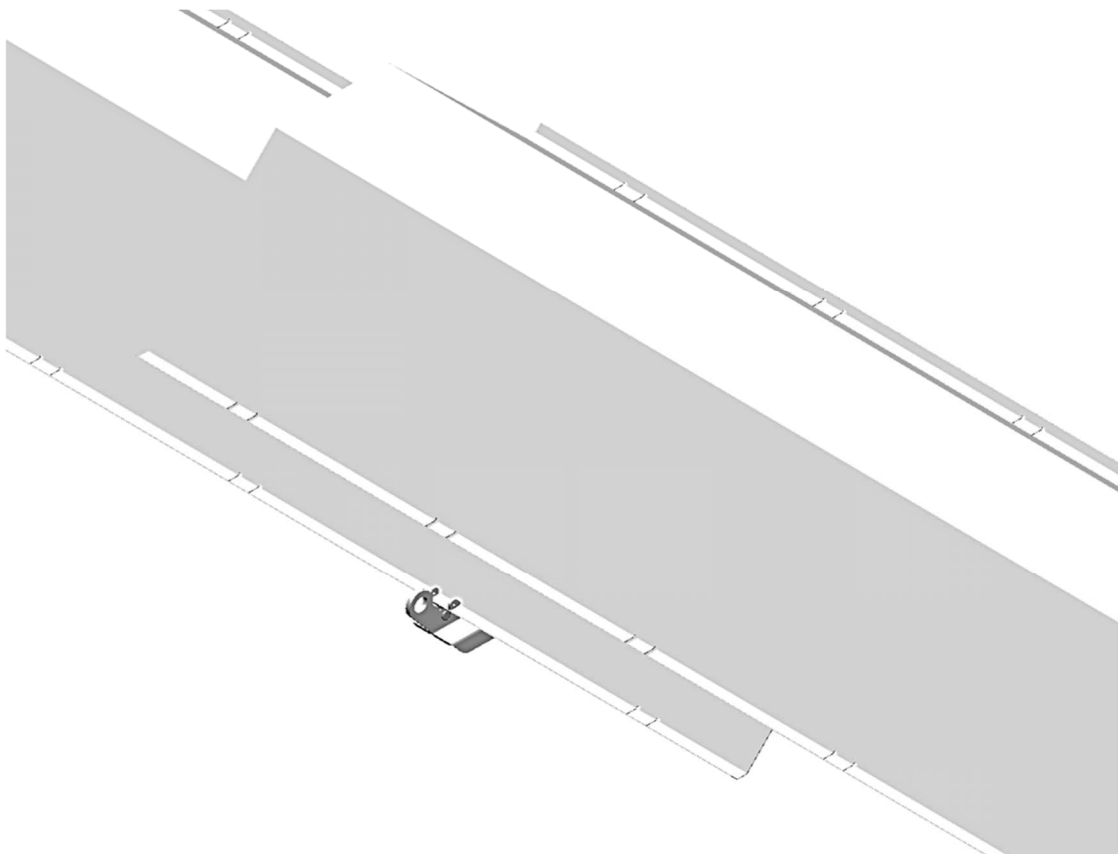

SOLARONICS Chauffage SA. 78 rue du Kimmel – CS20302 – 59429 ARMENTIERES CEDEX France

Tél : +3 (0)3.20.10.59.59 - Fax : +33 (0)3.20.35.57.22

Site : [www.solaronics.com](http://www.solaronics.com)

TECHNICAL INSTRUCTIONS GAS RADIANT TUBE SOLARHP L – NT15004E-GB – 10/11/2016

Clamp the cable fixation along the reflectors (one side only)

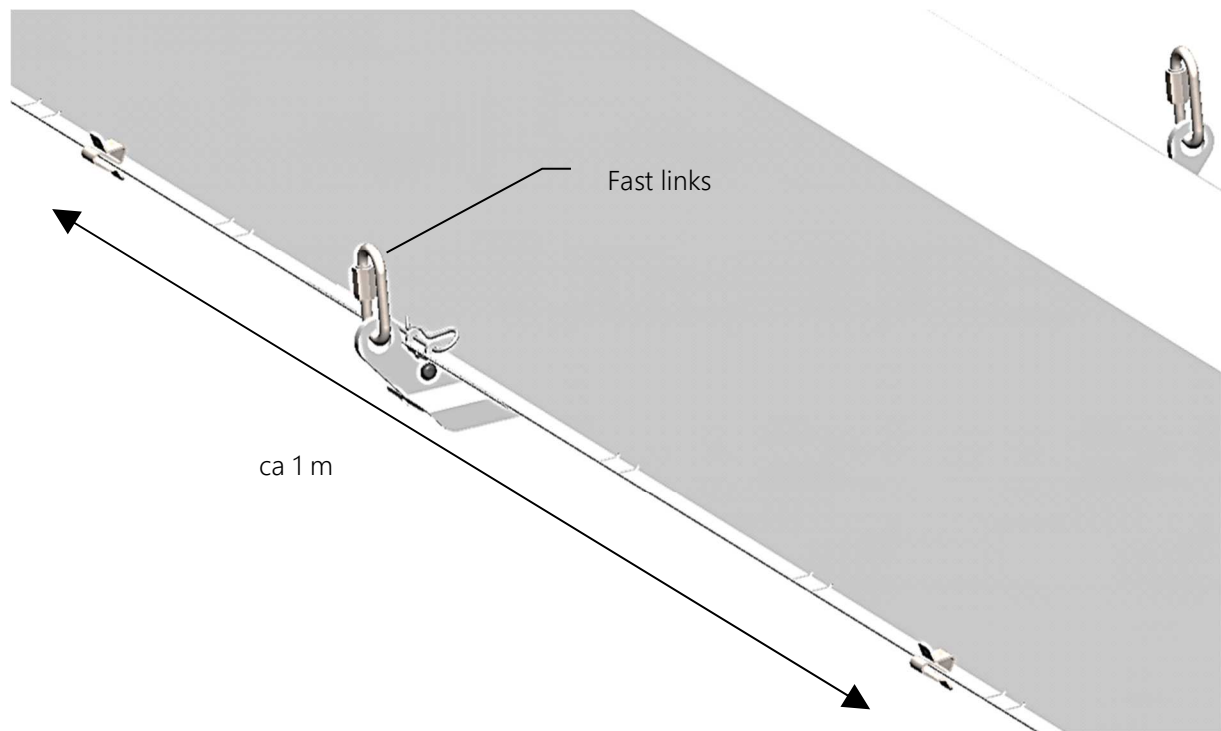

#### APPLIANCE IN HEIGHT:

Install and secure the appliance on a stable horizontal surface, adapted to its weight (trestles or other, minimum distance 0,5m from the floor)

Screw the tube extractor end **only** inside the beam (one single screw per heater)



#### AVERTISSEMENT

Do not screw on the other beams. This mistake can cause irreversible damages for the heater.

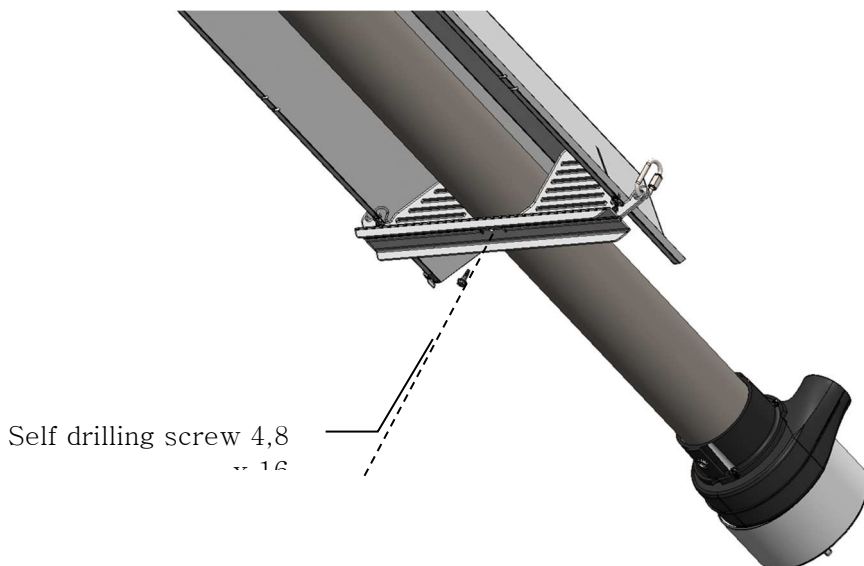

SOLARONICS Chauffage SA. 78 rue du Kimmel – CS20302 – 59429 ARMENTIERES CEDEX France

Tél : +3 (0)3.20.10.59.59 - Fax : +33 (0)3.20.35.57.22

Site : [www.solaronics.com](http://www.solaronics.com)

TECHNICAL INSTRUCTIONS GAS RADIANT TUBE SOLARHP L – NT15004E-GB – 10/11/2016

SolarHP L 23 and 36 : Insert the burner housing against the tube. The burner is installed on the straight pipe. The flared part used to connect the both pipes is on the pipe of the extractor.

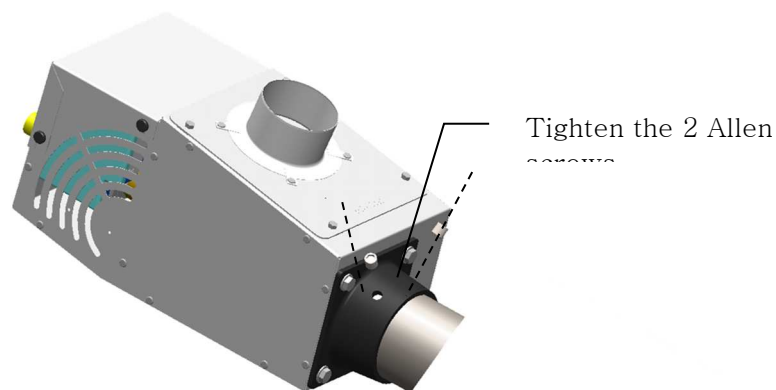

SolarHP L 23 and 36 : at the opposite side, trace 2 continuous rings of high temperature glue, at 20 and 40 mm from tube end. Insert the extractor fan against the tube. Plug the cable.

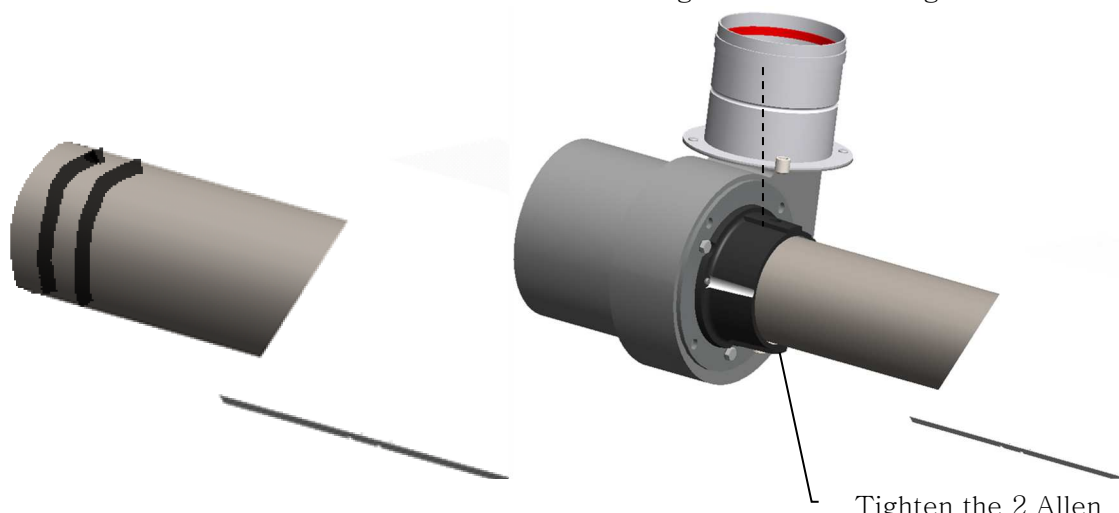

SolarHP L 50 : Insert the square gasket and screw the burner on the square flange of the tube



SOLARONICS Chauffage SA. 78 rue du Kemmel – CS20302 – 59429 ARMENTIERES CEDEX France

Tél : +3 (0)3.20.10.59.59 - Fax : +33 (0)3.20.35.57.22

Site : [www.solaronics.com](http://www.solaronics.com)

TECHNICAL INSTRUCTIONS GAS RADIANT TUBE SOLARHP L – NT15004E-GB – 10/11/2016

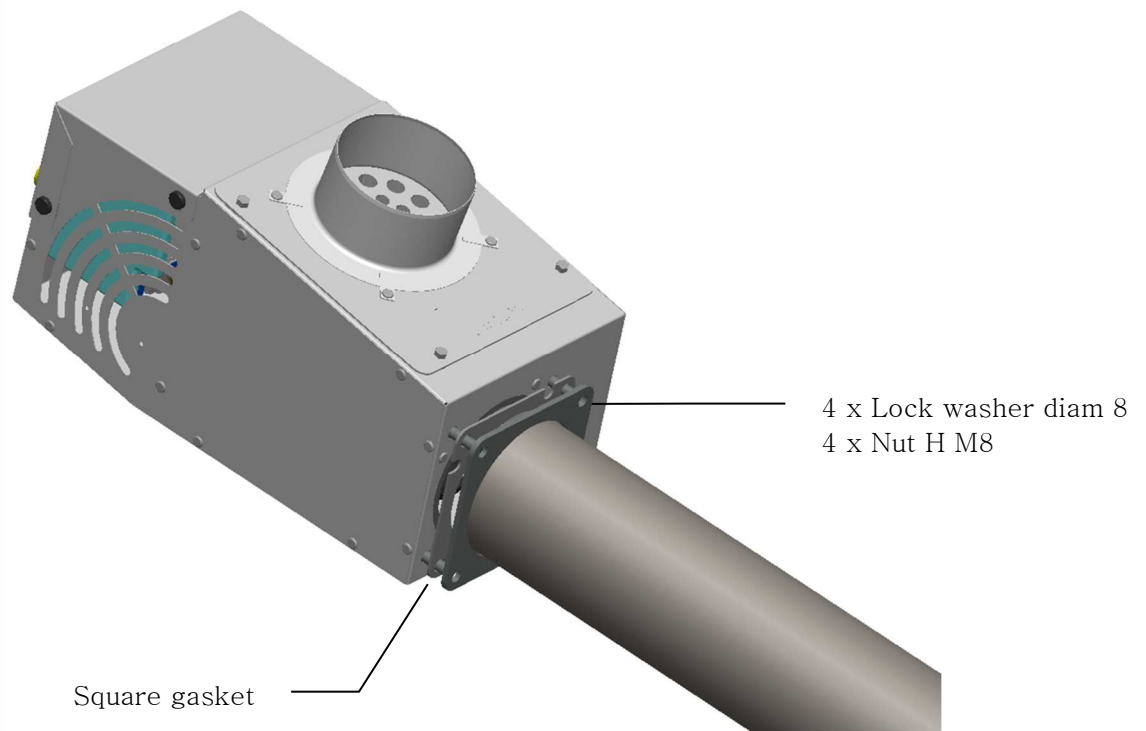

SolarHP L 50 : Insert the square gasket and screw the extractor fan on the square flange of the tube. Plug the cable

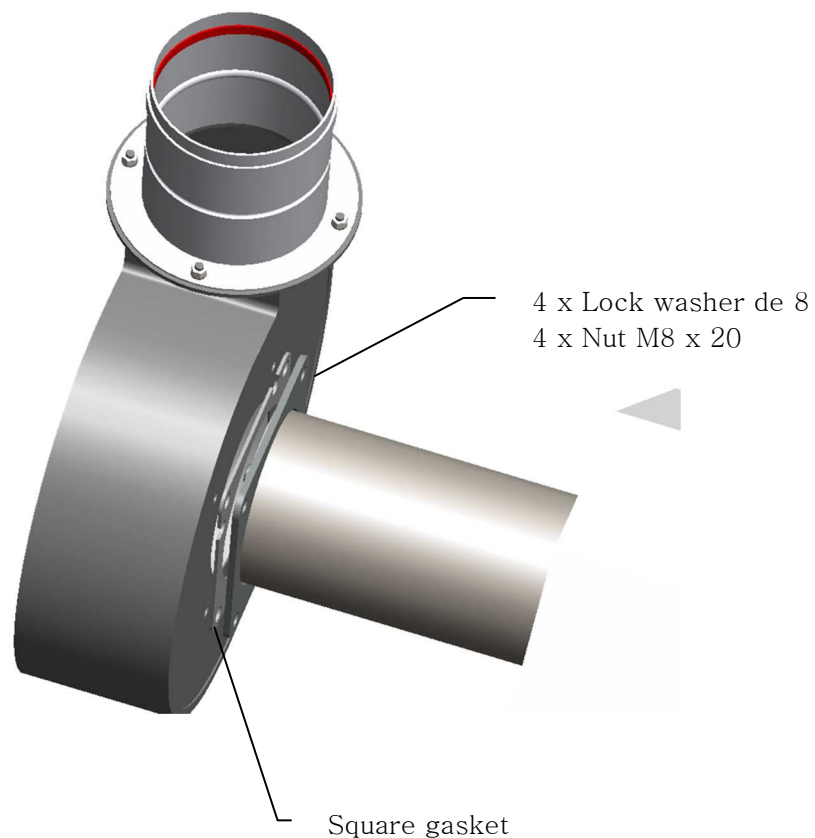

### 6.3. Implantation

The power, number, height and position of the radiant tubes SolarHP L have to be adjusted accordingly.



SOLARONICS Chauffage SA. 78 rue du Kemmel – CS20302 – 59429 ARMENTIERES CEDEX France

Tél : +3 (0)3.20.10.59.59 - Fax : +33 (0)3.20.35.57.22

Site : [www.solaronics.com](http://www.solaronics.com)

TECHNICAL INSTRUCTIONS GAS RADIANT TUBE SOLARHP L – NT15004E-GB – 10/11/2016



### 6.3.1. Recommended hanging heights

---

	SolarHP L 23	SolarHP L 36	SolarHP L 50
Min. recommended hanging height	3,5 m	5 m	6 m
Max. recommended hanging height	5 m	7 m	9 m

### 6.3.2. Tilt

---

If installed in a tilt position, a maximum tilt of 30° is recommended.

Extractor flue is then adjusted to vertical position in order to ease the flue pipes installation.

**Each hanging point must be fixed with 2 vertical chains or cables.**

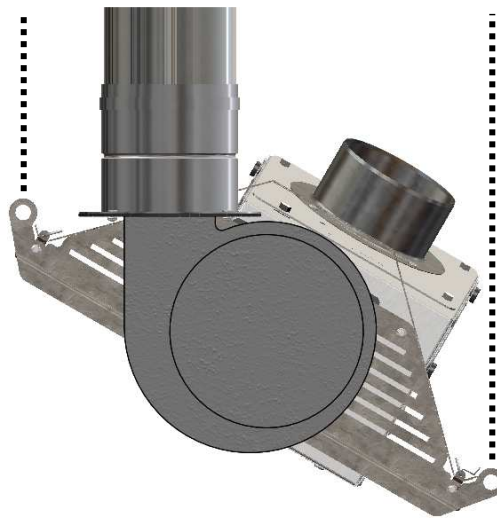

SOLARONICS Chauffage SA. 78 rue du Kemmel – CS20302 – 59429 ARMENTIERES CEDEX France

Tél : +3 (0)3.20.10.59.59 - Fax : +33 (0)3.20.35.57.22

Site : [www.solaronics.com](http://www.solaronics.com)

TECHNICAL INSTRUCTIONS GAS RADIANT TUBE SOLARHP L – NT15004E-GB – 10/11/2016

### 6.3.3. Handling for hanging

---

Lift the modules with a forklift elevator or a suitable lift aerial (dimensions and weight)

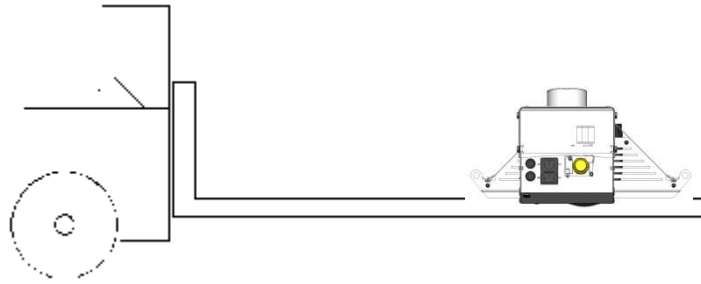

Anyway great care must be taken for the reflectors: install adequate protection on the lifting tool.

### 6.3.4. Hanging

---

Before fixing devices, it is advisable to make sure of the resistance of the support. **Apply a safety coefficient of 4 : each hanging point must withstand a weight = 4 x appliance weight / number of points.**

Generally speaking, the suspensions must be flexible (chains, ropes or steel cables) and the tensions between hanging points must be balanced. If the premise is equipped with an overhead crane and/or subjected to important vibrations the use of chains is strongly recommended.

The lengths of the suspensions shall not be lower than 0.9 m.

1st step:

- Check the support resistance

2nd step:

- Fix the device in 8, 12 or 16 points



SOLARONICS Chauffage SA. 78 rue du Kemmel – CS20302 – 59429 ARMENTIERES CEDEX France

Tél : +3 (0)3.20.10.59.59 - Fax : +33 (0)3.20.35.57.22

Site : [www.solaronics.com](http://www.solaronics.com)

TECHNICAL INSTRUCTIONS GAS RADIANT TUBE SOLARHP L – NT15004E-GB – 10/11/2016

- 26 -

## 6.4. Flue connection

The flue systems represented in this manual are those commonly used in the market. However, some of them are not usable in all countries. It is up to the installer or the building owners to ensure that the chosen flue system comply with the local installation rules.

Connection of the flue / air inlet shall be achieved:

- Either no connection to a flue or to a device for evacuating the products of combustion to the outside of the room in which the appliance is installed. (air flow ventilation must then be sufficient) - "A" type
- Either combustion air is taken from the building (air flow ventilation must then be sufficient) and the radiant tube is connected to a flue – "B" type



### WARNING

Flues, terminals and accessories used must compulsorily be approved (n°001-MG-Alu-DOP - Dry system), use only suction and discharge terminals referenced by SOLARONICS CHAUFFAGE, the use of non-approved equipment results in cancelling of the warranty.

The flue pipes junctions must be tight so to ease the assembly without damaging the seals some non aggressive lubricant shall be used. For instance: soapy solution

Radiant tube	Available pressure	Flue diameter	Flue pressure drop
SolarHP L 23	20 Pa	80 mm	1.5 Pa /m (flue) 9 Pa (terminal)
SolarHP L 36	40 Pa	100 mm	1.2 Pa /m (flue) 7 Pa (terminal)
SolarHP L 50	100 Pa	100 mm	2.3 Pa /m (flue) 13 Pa (terminal)

### 6.4.1. A type



SOLARONICS Chauffage SA. 78 rue du Kemmel – CS20302 – 59429 ARMENTIERES CEDEX France

Tél : +3 (0)3.20.10.59.59 - Fax : +33 (0)3.20.35.57.22

Site : [www.solaronics.com](http://www.solaronics.com)

TECHNICAL INSTRUCTIONS GAS RADIANT TUBE SOLARHP L – NT15004E-GB – 10/11/2016

This configuration is accepted in restrictive conditions. In particular the premise air flow ventilation must be sufficient.

Minimum air flow is:

	SolarHP L 23	SolarHP L 36	SolarHP L 50
Minimum ventilation air flow <u>for each</u> <u>installed appliance</u>	200 m3/h	350 m3/h	500 m3/h

#### 6.4.2. B type flue connexion

A flue evacuates the products of combustion to the outside of the room containing the appliance, through the roof or through a wall. The combustion air is drawn directly from the room.

The flue pipe should cross any room other than where the tube is installed.

Minimum air flow is:

	SolarHP L 23	SolarHP L 36	SolarHP L 50
Minimum ventilation air flow <u>for each</u> <u>installed appliance</u>	30 m3/h	45 m3/h	60 m3/h

#### 6.5. Gas connection

Firstly, you should check that the device you have received is consistent with the distributed gas group. To do this, you should refer to the information given on the heater data plate.

The gas supply must match the heater input and be equipped with all safety and control devices required in standards.

A detailed study will be carried out on pipe diameters depending on the nature of gas flow and the pipes length. It should ensure that pipes pressure drop does not exceed 5% of the supply pressure. The gas connections must be performed in accordance with indoor installations requirements regardless the type of gas, by qualified personnel having the applicable approvals.

Before commissioning, ensure that the gas line is tight and clean all residues caused by the work



#### WARNING

Before opening the gas network, check the valve tightness to the appliance.



SOLARONICS Chauffage SA. 78 rue du Kimmel – CS20302 – 59429 ARMENTIERES CEDEX France

Tél : +3 (0)3.20.10.59.59 - Fax : +33 (0)3.20.35.57.22

Site : [www.solaronics.com](http://www.solaronics.com)

TECHNICAL INSTRUCTIONS GAS RADIANT TUBE SOLARHP L – NT15004E-GB – 10/11/2016

The connecting of the device to the gas network by a flexible hose is also compulsory for:

- facilitating the assembly / dismantling,
- avoiding the transmission of mechanical constraints.

The assembly of the flexible hose is made by tightening in the hand follow-up of a tightening of a quarter of turn maximum with a key.



#### WARNING

A manual stop valve must be installed on the gas network nearby every radiant tube.

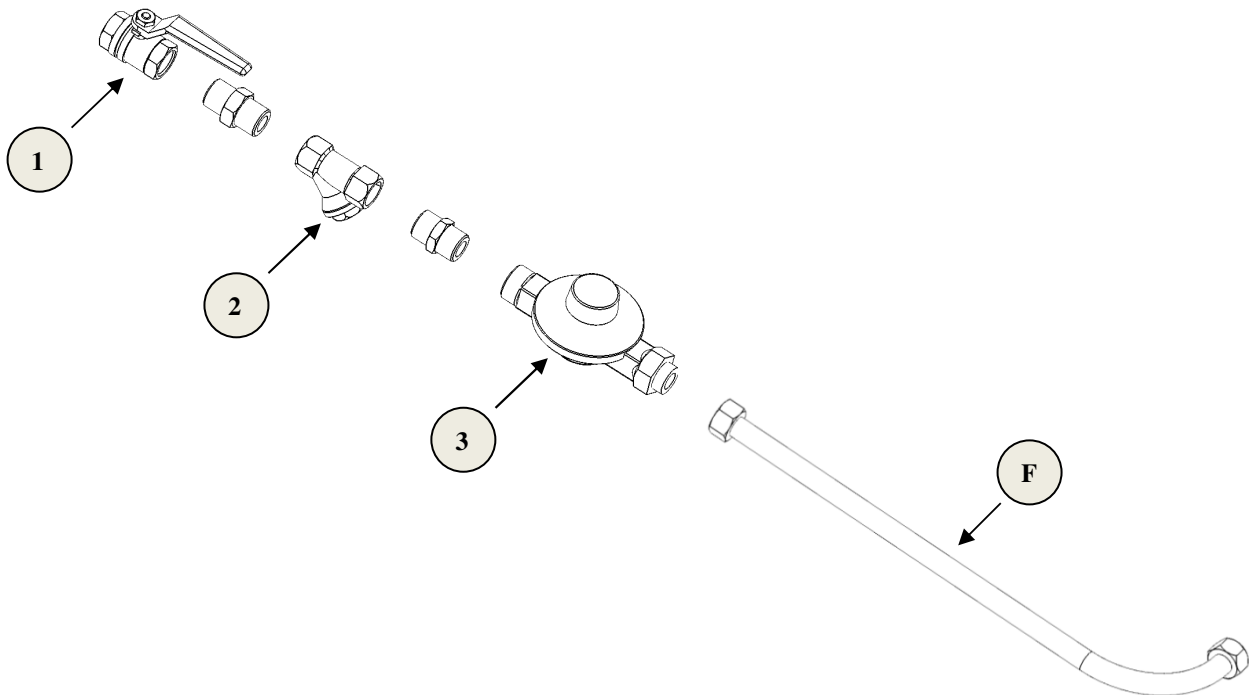

(1) Manual gas stop valve - (2) gas filter - (3) gas regulator

(F) Flexible pipe

*Example of gas connection*



SOLARONICS Chauffage SA. 78 rue du Kemmel – CS20302 – 59429 ARMENTIERES CEDEX France

Tél : +3 (0)3.20.10.59.59 - Fax : +33 (0)3.20.35.57.22

Site : [www.solaronics.com](http://www.solaronics.com)

TECHNICAL INSTRUCTIONS GAS RADIANT TUBE SOLARHP L – NT15004E-GB – 10/11/2016

## 7. Temperature control - electrical connection

### 7.1. Temperature control

The regulation of temperature is made in an on/off mode by switching the power supply of devices.

The temperature of comfort of the radiant devices is measured by a probe with black ball, which determines the resultant temperature between the air temperature and the radiation emitted by devices.

Solaronics Chauffage developed a range of specific regulation. These equipments are delivered cabled and with their electric drawing

Plan :

- 1 probe with black ball by zone
- 1 shielded cable 2 x 1 mm<sup>2</sup> by zone to connect the probe with the regulation

Besides the respect of instructions during the installation of a set of regulation, it is advisable of:

- Positioning the probe at head level in a zone not subjected to drafts and receiving a radiation in a homogeneous way.
- Fixing the probe on the heat insulator material of the wall, when this support is chosen. The wall emits a cold radiation, opposing the good measure of the probe

### 7.2. Electrical connections

#### 7.2.1. Connections

- Check the power supply: 230 Volts (+10%,-15%) 50 Hz, no neutral impedance (i.e. 0V between neutral and earth). In case of neutral impedance, an isolation transformer is compulsory.
- Plug the extractor fan supply cord inside the burner housing female plug
- Plug the mains supply cord inside the male plug : Line; Neutral and Ground
- Plug the optional cord(s) : 2<sup>nd</sup> step and/or flame presence

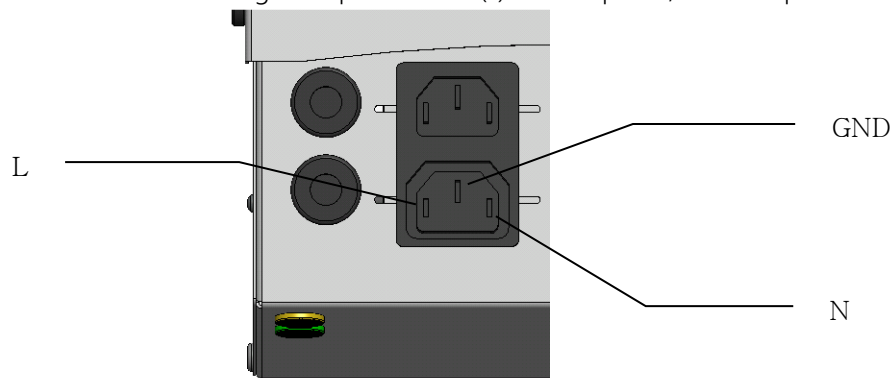

SOLARONICS Chauffage SA. 78 rue du Kimmel – CS20302 – 59429 ARMENTIERES CEDEX France

Tél : +3 (0)3.20.10.59.59 - Fax : +33 (0)3.20.35.57.22

Site : [www.solaronics.com](http://www.solaronics.com)

TECHNICAL INSTRUCTIONS GAS RADIANT TUBE SOLARHP L – NT15004E-GB – 10/11/2016

*Burner housing connexion*

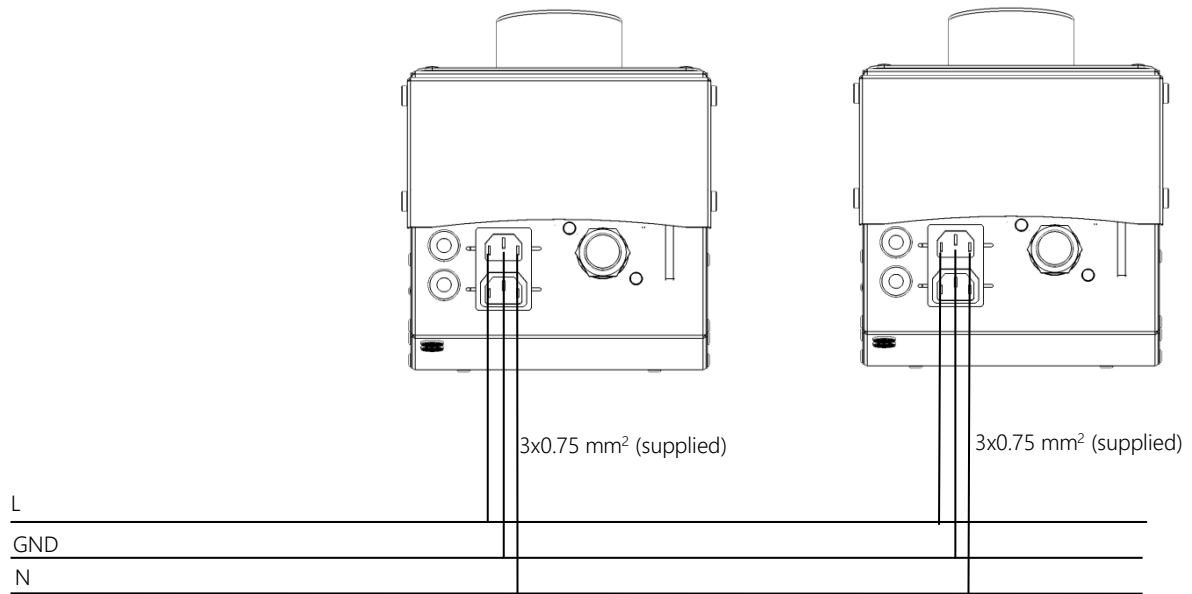

*MAINS + ELECTRICAL PROTECTION*

*CONTROL*

3G 1.5 mm<sup>2</sup> (size section according to the number of units)

*Electrical connection for standard units*



SOLARONICS Chauffage SA. 78 rue du Kemmel – CS20302 – 59429 ARMENTIERES CEDEX France

Tél : +3 (0)3.20.10.59.59 - Fax : +33 (0)3.20.35.57.22

Site : [www.solaronics.com](http://www.solaronics.com)

TECHNICAL INSTRUCTIONS GAS RADIANT TUBE SOLARHP L – NT15004E-GB – 10/11/2016

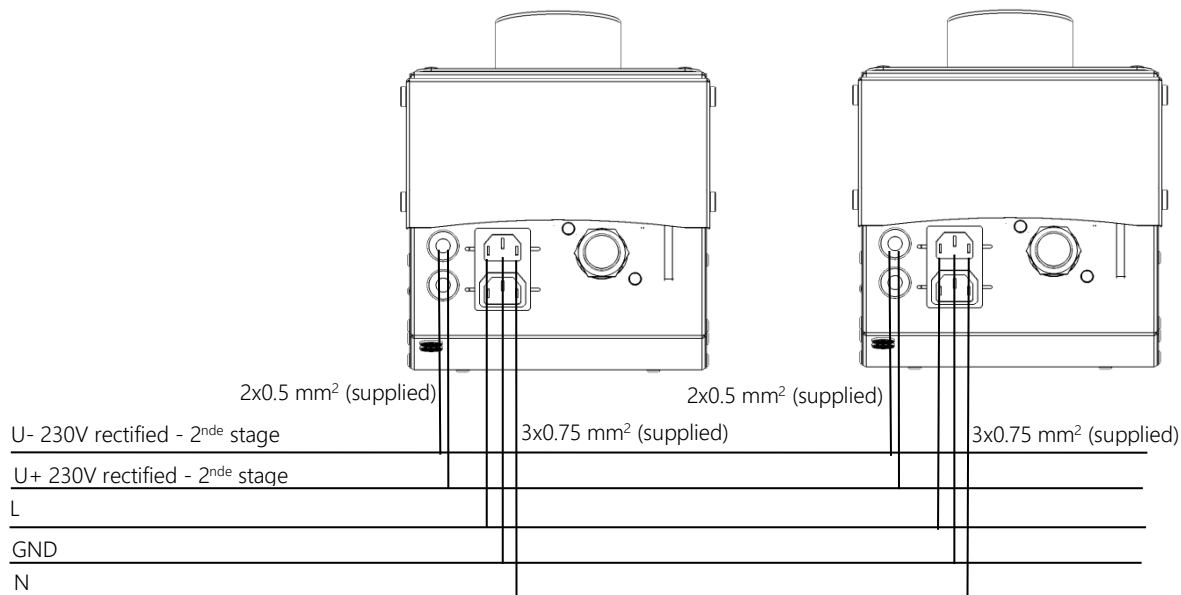

*MAINS + ELECTRICAL PROTECTION*

*CONTROL*

5G 1.5 mm<sup>2</sup> (size section according to the number of units)

*Electrical connection for 2-stages units*

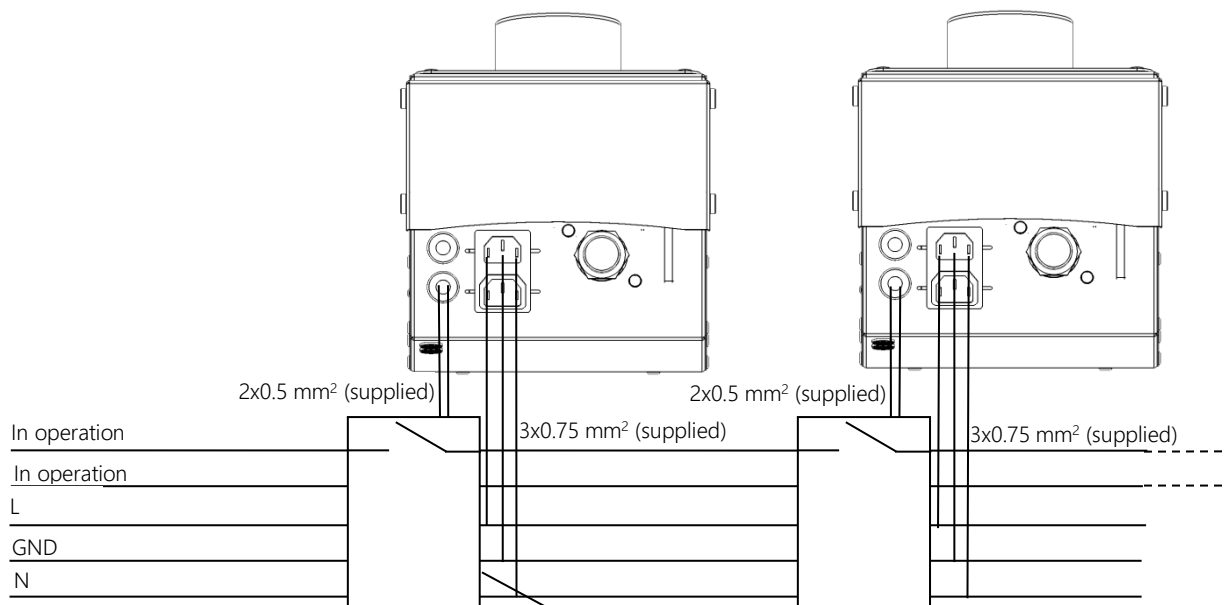

*MAINS + ELECTRICAL PROTECTION*

*CONTROL*

5G 1.5 mm<sup>2</sup> (size section according to the number of units)

Derivation box and in operation signal (supplied)

*Electrical connection - In operation signal in option*



SOLARONICS Chauffage SA. 78 rue du Kimmel – CS20302 – 59429 ARMENTIERES CEDEX France

Tél : +3 (0)3.20.10.59.59 - Fax : +33 (0)3.20.35.57.22

Site : [www.solaronics.com](http://www.solaronics.com)

TECHNICAL INSTRUCTIONS GAS RADIANT TUBE SOLARHP L – NT15004E-GB – 10/11/2016



## 7.2.2. Electrical drawing

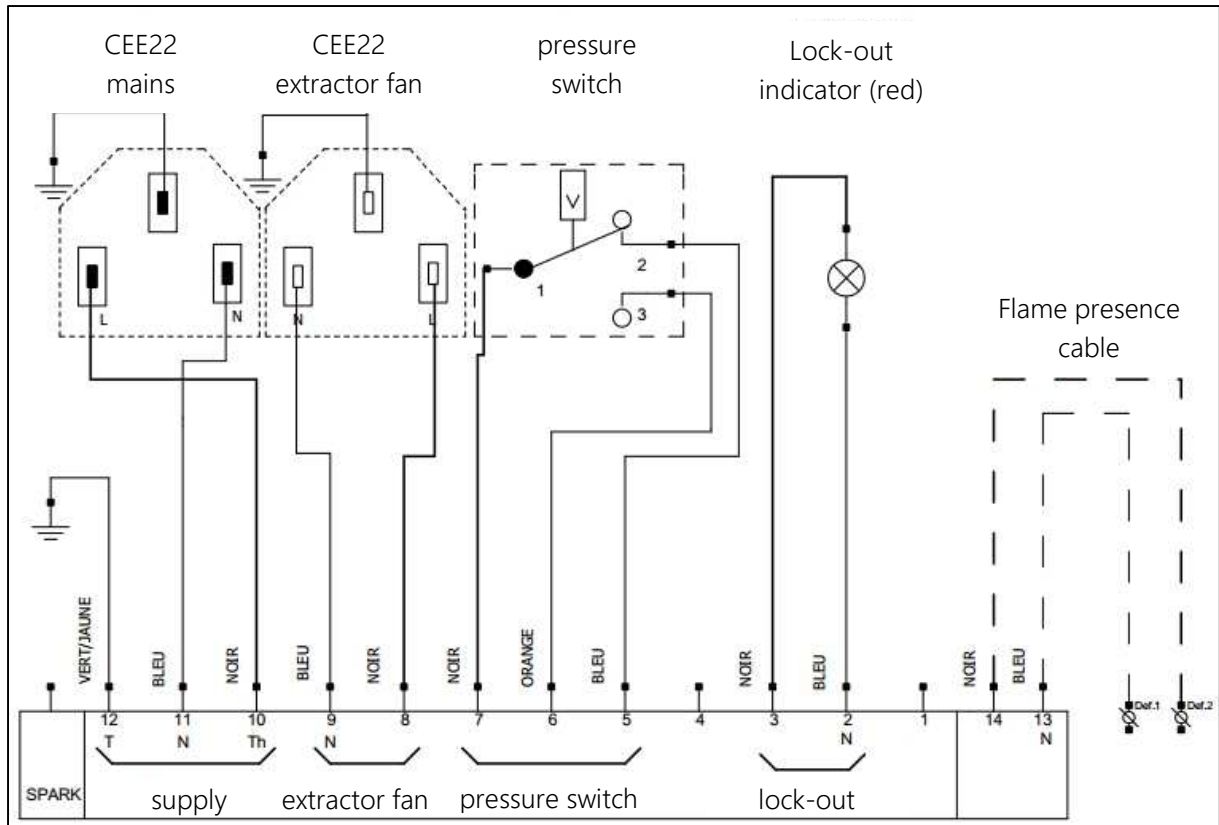

----- Flame presence option: voltage (230V Line) indicates flame presence



SOLARONICS Chauffage SA. 78 rue du Kimmel – CS20302 – 59429 ARMENTIERES CEDEX France

Tél : +3 (0)3.20.10.59.59 - Fax : +33 (0)3.20.35.57.22

Site : [www.solaronics.com](http://www.solaronics.com)

TECHNICAL INSTRUCTIONS GAS RADIANT TUBE SOLARHP L – NT15004E-GB – 10/11/2016

----- Optional burner 2<sup>nd</sup> step is 230V RAC

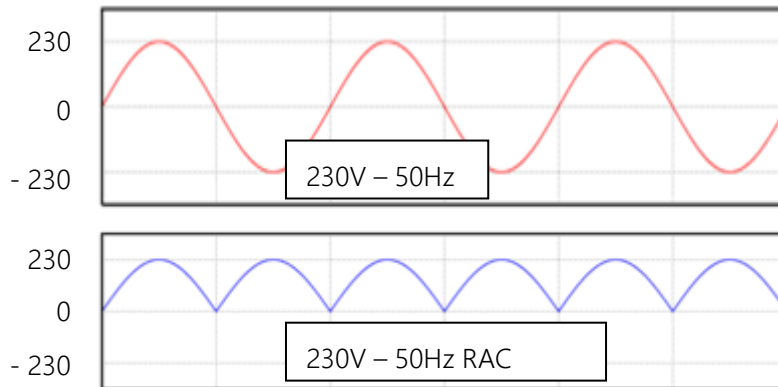
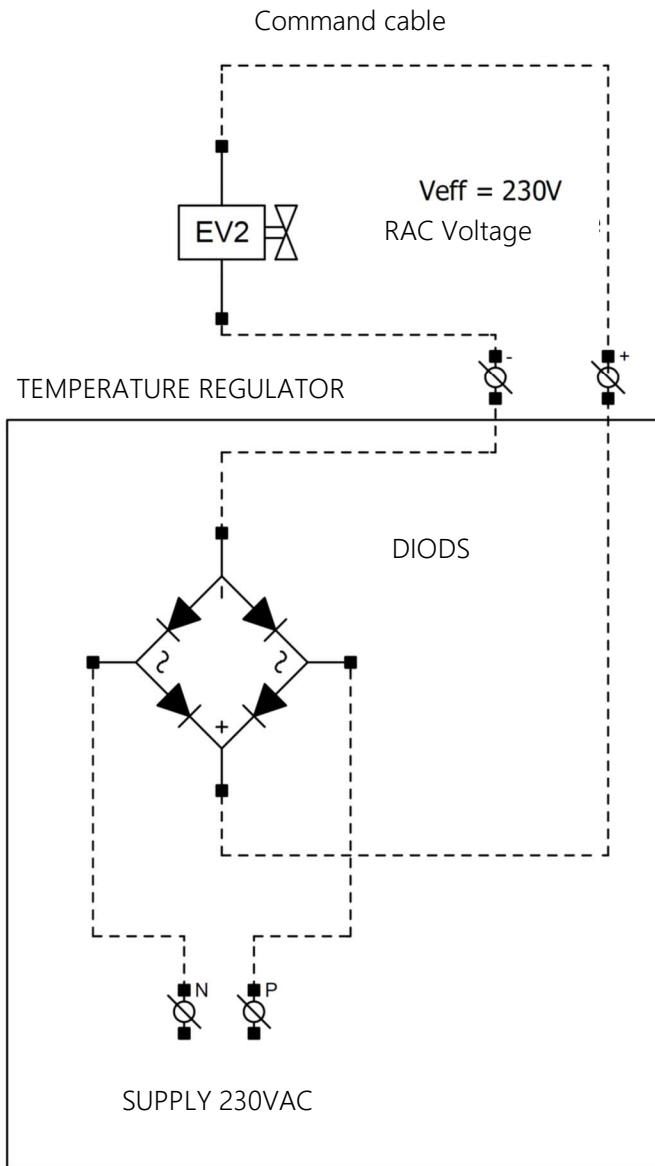

SOLARONICS Chauffage SA. 78 rue du Kemmel – CS20302 – 59429 ARMENTIERES CEDEX France

Tél : +3 (0)3.20.10.59.59 - Fax : +33 (0)3.20.35.57.22

Site : [www.solaronics.com](http://www.solaronics.com)

TECHNICAL INSTRUCTIONS GAS RADIANT TUBE SOLARHP L – NT15004E-GB – 10/11/2016

## 8. Commissioning

---

### 8.1. Start-up

---

1- Before commissioning and turning on the heater, check that all connections have been carried out as defined above:

- § "Flue connection"
- § "Gas connection"
- § "Electrical connection"

Check also:

- Distances around the heater are respected
- That all electrical components connections are made
- That earth connection is effective

2- Check the supply voltage at the heater terminals. The voltage value must be between 210 V and 230 V (AC).

3- Check that the gas type and supply pressure comply with the appliance. Check that the general gas valve is open, purge the gas line. Open manual stop valve upstream of each appliance.

4- Check on the temperature controller that no sensor is faulty

5- Switch on the heaters.

On the control, increase the set point temperature to a value higher by more than 1°C to the room temperature, then switch to automatic mode

6- Set the controller (refer to the its instructions)

Nota : The appliances are factory preset, however the setting values can be corrected. This correction may be necessary when the appliances are installed at altitudes above 500 metres. Indeed, the atmospheric pressure is lower, the quality of combustion is affected. For this operation, refer to § "Burner Setting"

6- Set the controller (  refer to the its instructions)



SOLARONICS Chauffage SA. 78 rue du Kimmel – CS20302 – 59429 ARMENTIERES CEDEX France

Tél : +3 (0)3.20.10.59.59 - Fax : +33 (0)3.20.35.57.22

Site : [www.solaronics.com](http://www.solaronics.com)

TECHNICAL INSTRUCTIONS GAS RADIANT TUBE SOLARHP L – NT15004E-GB – 10/11/2016

## 8.2. Burner setting

This operation must be performed by a qualified professional, equipped with a combustion analyser.

Before any work, disconnect the power and gas supplies.

Remark: When changing gas, the label "setting gas" located inside the heater door must be modified to indicate the new setting.



### WARNING

Check for gas leaks after each intervention.

Tools needed:

- Screwdriver (slotted and cross)
- 10 mm wrench
- Combustion analyzer (CO<sub>2</sub> - CO - Flue gas temperature) set to the type of supply gas
- Gas gauge (max pressure 50 mbar)

### Burner control and adjustment process:

- 1) Calibrate the combustion analyser and place the rod in the flue.
- 2) Check the gas supply pressure before ignition, in Off mode
- 3) Start the burner at full power (  refer to the controller specific instructions)
  - Check gas supply pressure (see table)
  - After 2 minutes of operation, check the gas pressure at the injector
  - Adjust if needed the injector pressure value with the screw/nut according to the table below
  - Once the first step setting also done, return to normal control

Gas	Supply pressure	Step	Injector pressure (mbar)		
			SolarHP L 23	SolarHP L 36	SolarHP L 50
G20 (H)	17 - 25 mbar	1 <sup>st</sup> (*)	6	6	6
		2 <sup>nd</sup>	10	10	10
G25 (L)	20 - 30 mbar	1 <sup>st</sup> (*)	9,5	9,5	9,5
		2 <sup>nd</sup>	15	15	15
G31 (LPG)	25 - 45 mbar	1 <sup>st</sup> (*)	15	15	15
		2 <sup>nd</sup>	25	25	25

(\*) for appliances with option 2-step burner



SOLARONICS Chauffage SA. 78 rue du Kimmel – CS20302 – 59429 ARMENTIERES CEDEX France

Tél : +3 (0)3.20.10.59.59 - Fax : +33 (0)3.20.35.57.22

Site : [www.solaronics.com](http://www.solaronics.com)

TECHNICAL INSTRUCTIONS GAS RADIANT TUBE SOLARHP L – NT15004E-GB – 10/11/2016

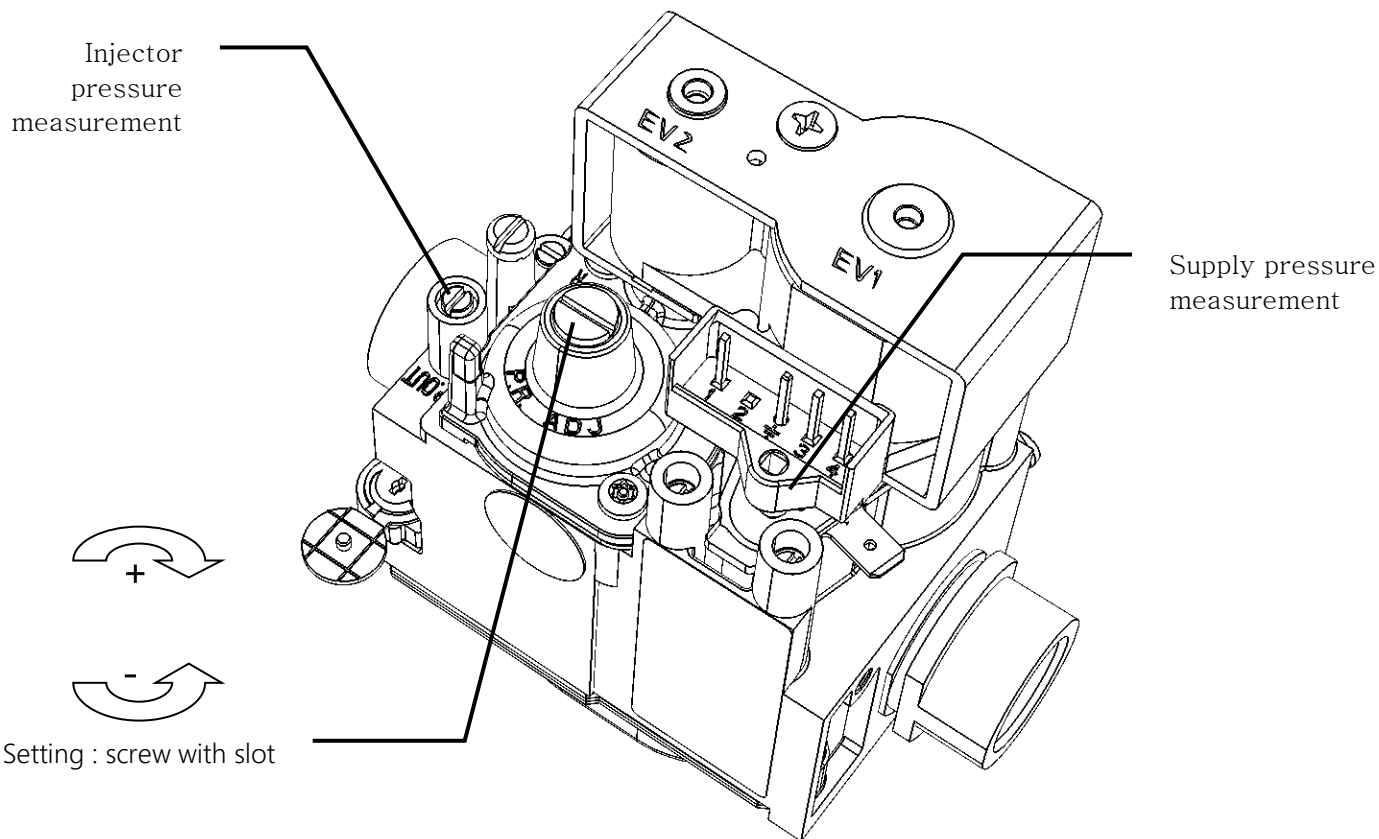

*1-step valve setting*

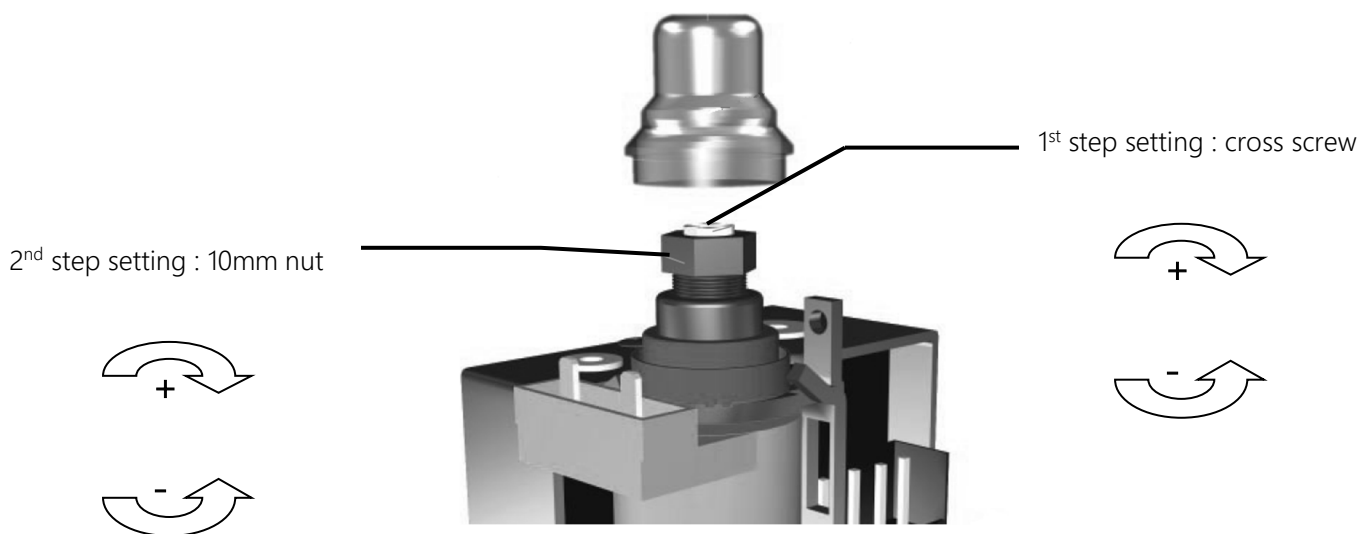

- Set 2<sup>nd</sup> step **BEFORE** and 1<sup>st</sup> step after
- Keep the 10mm nut tightened with a key when setting the 1<sup>st</sup> step screw

*2-step valve setting*



SOLARONICS Chauffage SA. 78 rue du Kimmel – CS20302 – 59429 ARMENTIERES CEDEX France

Tél : +3 (0)3.20.10.59.59 - Fax : +33 (0)3.20.35.57.22

Site : [www.solaronics.com](http://www.solaronics.com)

TECHNICAL INSTRUCTIONS GAS RADIANT TUBE SOLARHP L – NT15004E-GB – 10/11/2016

## 9. Troubleshooting

### 9.1. Troubleshooting

In case of problem, always check that prerequisites in the smooth running of unit ("Start up" section) are performed.  
If the burner control is locked out (red indicator is switched on) reset it.



#### WARNING

All electrical or mechanical interventions should be made when the power is turned off and the gas supply closed.

Symptoms		Possible causes	Remedy
Lighting and flame control device	Burner and extractor fan		
No high voltage sparks between electrode and earth	Extractor is not working	<ul style="list-style-type: none"> <li>- Red indicator OFF : no voltage</li> <li>- Extractor unplugged</li> </ul>	<ul style="list-style-type: none"> <li>- Check power supply and plugs</li> <li>- Check the extractor plug</li> </ul>
	Extractor is working	<ul style="list-style-type: none"> <li>- Defective pressure switch</li> <li>- Tube unplugged</li> <li>- Electrode to the ground</li> <li>- Unplugged electrode or ground problem</li> <li>- Defective burner control</li> </ul>	<ul style="list-style-type: none"> <li>- Replace</li> <li>- Plug the tube</li> <li>- Replace</li> <li>- Check connections</li> <li>- Replace</li> </ul>
The light-up cycle proceeds normally with HV sparks between electrode and earth	Does not light up upon the first attempt	<ul style="list-style-type: none"> <li>- Manual stop valve shut</li> <li>- Gas lines inadequately bled</li> </ul>	<ul style="list-style-type: none"> <li>- Turn valve on</li> <li>- Bleed the gas lines</li> </ul>
	Does not light up after several attempts	<ul style="list-style-type: none"> <li>- Filter ahead the reducer clogged</li> <li>- Injector clogged or partially clogged</li> <li>- Ill-suited injector</li> <li>- Electrovalve jammed in 'off' position</li> </ul>	<ul style="list-style-type: none"> <li>- Clean the filter</li> <li>- Clean the injector</li> <li>- Replace injector</li> <li>- Replace the electrovalve</li> </ul>



SOLARONICS Chauffage SA. 78 rue du Kimmel – CS20302 – 59429 ARMENTIERES CEDEX France

Tél : +3 (0)3.20.10.59.59 - Fax : +33 (0)3.20.35.57.22

Site : [www.solaronics.com](http://www.solaronics.com)

Symptoms		Possible causes	Remedy
Lighting and flame control device	Burner and extractor fan		
	The burner lights up but stops within 10 seconds upon light-up	<ul style="list-style-type: none"> <li>- Overpressure at the injector</li> <li>- Ill-suited injector</li> <li>- Electrode badly positioned in relation to burner or earth</li> <li>- Poor grounding on burner control</li> <li>- The burner control is defective (ionisation control is too slack)</li> <li>- Phase-neutral inversion</li> <li>- Neutral impedance</li> </ul>	<ul style="list-style-type: none"> <li>- Adjust the pressure</li> <li>- Replace the injector</li> <li>- Reposition the electrode</li> <li>- Clean point contact</li> <li>- Replace the burner control</li> <li>- Connect properly</li> <li>- Fit in an isolation transformer</li> </ul>
	The burner lights up but stops within 30 seconds upon light-up	<ul style="list-style-type: none"> <li>- Leaking tube assembly</li> <li>- Leaking flue assembly</li> </ul>	<ul style="list-style-type: none"> <li>- Tighten tube assembly</li> <li>- Tighten flue assembly</li> </ul>
	2 <sup>nd</sup> step valve coil is noisy (buzzing)	<ul style="list-style-type: none"> <li>- Coil is supplied with 230Vac</li> <li>- Regulator connexion is wrong</li> </ul>	<ul style="list-style-type: none"> <li>- Check electric connection of coil, burner and regulator</li> </ul>



#### WARNING

Only genuine manufacturer parts ensure product and people safety. The use of parts other than genuine ones invokes the responsibility of the individual and will void the product warranty.



SOLARONICS Chauffage SA. 78 rue du Kemmel – CS20302 – 59429 ARMENTIERES CEDEX France

Tél : +3 (0)3.20.10.59.59 - Fax : +33 (0)3.20.35.57.22

Site : [www.solaronics.com](http://www.solaronics.com)

## 9.2. Spare parts

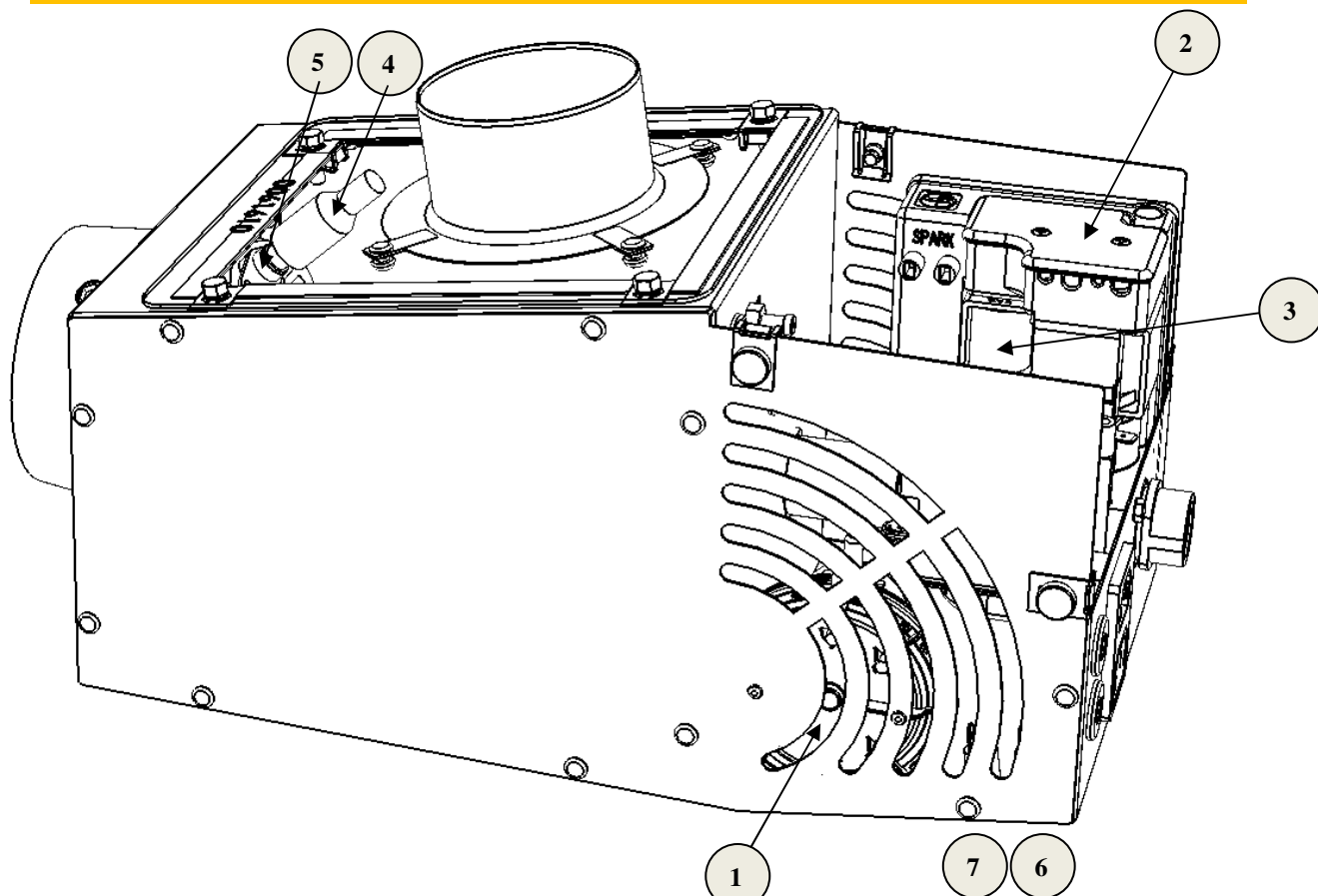

N°	Designation	Reference
1	Pressure switch	9422018
2	Burner control	9424180
3	1 step gas valve	9421390
3	2 step gas valve	9421395
4	Electrode cable	9412008
5	Electrode	9412007
6	Orange indicator light	0074540
7	Red indicator light	0074544
8	Extractor SolarHP L 23	8011521
	Extractor SolarHP L 36	8011541
	Extractor SolarHP L 50	8011551
9	High temperature cable SolarHP L 23	8015023
	High temperature cable SolarHP L 36	8015036
	High temperature cable SolarHP L 50	8015050



### WARNING

Do contact SOLARONICS CHAUFFAGE before replacing any other parts.

## 10. Maintenance



SOLARONICS Chauffage SA. 78 rue du Kimmel – CS20302 – 59429 ARMENTIERES CEDEX France

Tél : +3 (0)3.20.10.59.59 - Fax : +33 (0)3.20.35.57.22

Site : [www.solaronics.com](http://www.solaronics.com)

TECHNICAL INSTRUCTIONS GAS RADIANT TUBE SOLARHP L – NT15004E-GB – 10/11/2016



A proper and regular maintenance, at least once a year, determine an efficient and effective functioning, a minimum gas consumption and an important longevity.



**WARNING**

The gas device must be maintained cold and with electric power cut

These works can be performed by a qualified technician only

Part	Operation
Flue pipes	Check the air inlet and flue pipes. The pipes must be tight to flue gases and resistant to corrosion. The flue pipes must be swept every year.
Radiant tube	Inspection Cleaning when needed
Burner	Clean the burner and injector with a brush and/or vacuum cleaner
Electrode	Check aspect and clean with a solvent if needed
Extractor fan	Check aspect and free rotation
Pressure switch	Check good working
Combustion	Check gas pressures and analyse flue gases During checking make sure that the probe is tight at sampling point, the probe end should be at the center of the flue pipe



SOLARONICS Chauffage SA. 78 rue du Kemmel – CS20302 – 59429 ARMENTIERES CEDEX France

Tél : +3 (0)3.20.10.59.59 - Fax : +33 (0)3.20.35.57.22

Site : [www.solaronics.com](http://www.solaronics.com)

TECHNICAL INSTRUCTIONS GAS RADIANT TUBE SOLARHP L – NT15004E-GB – 10/11/2016

## 11. Warranty

---

Your appliance has a contractual warranty against any manufacturing defect.

Solaronics Chauffage is not responsible for improper use of the device, failure or insufficient maintenance, or improper installation of the appliance (it is your responsibility to ensure that it is carried out by a qualified professional).

In particular, Solaronics Chauffage will not be liable for any damage, loss or injury caused by improper installation that does not comply:

- with rules in force or imposed by the local authorities
- with national, or even local and specific rules governing the installation
- with our technical instructions, in particular, for maintenance of the devices
- with the good engineering practice

Solaronics Chauffage warranty is limited to replacement or repair of defective parts only by our services excluding labor costs, travel and transport.

Our warranty does not cover replacement or repair of damaged parts by normal wear and tear, misuse, unskilled third party interventions, defect or failure in monitoring or maintenance, non-compliant power supply or use of an inappropriate fuel or of poor quality.

Subsets, such as motors, pumps, electric valves, etc ... are only guaranteed if they have never been removed.

Rights established by the European Directive 1999/44/CEE remain valid.



SOLARONICS Chauffage SA. 78 rue du Kemmel – CS20302 – 59429 ARMENTIERES CEDEX France

Tél : +3 (0)3.20.10.59.59 - Fax : +33 (0)3.20.35.57.22

Site : [www.solaronics.com](http://www.solaronics.com)

TECHNICAL INSTRUCTIONS GAS RADIANT TUBE SOLARHP L – NT15004E-GB – 10/11/2016

## 12. Information

Model identifier : <b>SolarHPL 23</b>							
Type of heating : <b>Radiant tube</b>							
<b>Fuel</b>		<b>Fuel</b>		Space heating emissions(*)			
				NOx			
Select fuel type		<b>Gaseous</b>		<b>G20/G25 /G31</b>		<b>122 mg/kWh input(GCV)</b>	
<b>Characteristics when operating with the preferred fuel only</b>							
Item	Symbol	Value	Unit	Item	Symbol	Value	Unit
<b>Heat output</b>				<b>Useful efficiency (GCV) – Tube local space heaters only</b>			
Nominal heat output	P <sub>nom</sub>	18	kW	Useful efficiency (GCV) at nominal heat output	$\eta_{th, nom}$	81,1	%
Minimum heat output	P <sub>min</sub>	(N.A)	kW	Useful efficiency at minimum heat output	$\eta_{th, min}$	(N.A)	%
Minimum heat output ( as percentage of nominal heat output)	..	(N.A)	%				
Nominal tube system heat output ( if applicable)	P système	(N.A)	kW				
Nominal tube segment heat output (if applicable)	P heater	(N.A)	kW	Useful efficiency of tube segment at minimum heat output ( if applicable)	$\eta_i$	(N.A)	%
(Repeat for multiple segment, if applicable)	..	(N.A)	kW	(repeat for multiple segments, if applicable)	..	(N.A)	%
Number of identical tube segments	n	(N.A)	(-)				
<b>Radiant factor</b>				<b>Envelope losses</b>			
Radiant factor at nominal heat output	RF <sub>nom</sub>	58,5	(-)	Envelope insulation class	U	(N.A)	W/ (m²K)
Radiant factor at minimum heat output	RF <sub>min</sub>	(N.A)	(-)	Envelope loss factor	F <sub>env</sub>	(N.A)	%
Radiant factor of tube segment at nominal heat output	RF <sub>i</sub>	(N.A)	(-)	Heat generator to be installed outside the heated area		No	



SOLARONICS Chauffage SA. 78 rue du Kimmel – CS20302 – 59429 ARMENTIERES CEDEX France

Tél : +3 (0)3.20.10.59.59 - Fax : +33 (0)3.20.35.57.22

Site : [www.solaronics.com](http://www.solaronics.com)

TECHNICAL INSTRUCTIONS GAS RADIANT TUBE SOLARHP L – NT15004E-GB – 10/11/2016

(repeat for multiple segments, if applicable)	..						
<b>Auxiliary electricity consumption</b>				<b>Heat output control type ( select one)</b>			
At nominal heat output	el max	0,058	kW	Single stage	yes		
At minimum heat output	el min	0,058	kW	Two stage	no		
In standby mode	el SB	(N.A)	kW	Modulating	no		
<b>Permanent pilot flame power requirement</b>							
Pilot flame power requirement (if applicable)	P pilot	(N.A)	kW				
Contact details	SOLARONICS Chauffage SA. 78 rue du Kimmel - B.P. 30173 – 59428 ARMENTIERES CEDEX France						
(*) NOx = nitrogen oxides							



SOLARONICS Chauffage SA. 78 rue du Kimmel – CS20302 – 59429 ARMENTIERES CEDEX France

Tél : +3 (0)3.20.10.59.59 - Fax : +33 (0)3.20.35.57.22

Site : [www.solaronics.com](http://www.solaronics.com)

TECHNICAL INSTRUCTIONS GAS RADIANT TUBE SOLARHP L – NT15004E-GB – 10/11/2016

Model identifier : <b>SolarHPL 23 2 stages</b>							
Type of heating : <b>Radiant tube</b>							
<b>Fuel</b>		<b>Fuel</b>		Space heating emissions(*)			
				NOx			
Select fuel type		<b>Gaseous</b>		<b>G20/G25 /G31</b>		<b>122 mg/kWh input(GCV)</b>	
<b>Characteristics when operating with the preferred fuel only</b>							
Item	Symbol	Value	Unit	Item	Symbol	Value	Unit
<b>Heat output</b>				<b>Useful efficiency (GCV) – Tube local space heaters only</b>			
Nominal heat output	P <sub>nom</sub>	18	kW	Useful efficiency (GCV) at nominal heat output	$\eta_{th, nom}$	81,1	%
Minimum heat output	P <sub>min</sub>	13,6	kW	Useful efficiency (GCV) at minimum heat output	$\eta_{th, min}$	78,8	%
Minimum heat output ( as percentage of nominal heat output)	..	75,3	%				
Nominal tube system heat output ( if applicable)	P système	(N.A)	kW				
Nominal tube segment heat output (if applicable)	P heater	(N.A)	kW	Useful efficiency of tube segment at minimum heat output ( if applicable)	$\eta_i$	(N.A)	%
(Repeat for multiple segment, if applicable)	..	(N.A)	kW	(repeat for multiple segments, if applicable)	..	(N.A)	%
Number of identical tube segments	n	(N.A)	(-)				
<b>Radiant factor</b>				<b>Envelope losses</b>			
Radiant factor at nominal heat output	RF <sub>nom</sub>	58,5	(-)	Envelope insulation class	U	(N.A)	W/ (m²K)
Radiant factor at minimum heat output	RF <sub>min</sub>	58,5	(-)	Envelope loss factor	F <sub>env</sub>	(N.A)	%
Radiant factor of tube segment at nominal heat output	RF <sub>i</sub>	(N.A)	(-)	Heat generator to be installed outside the heated area		No	



SOLARONICS Chauffage SA. 78 rue du Kimmel – CS20302 – 59429 ARMENTIERES CEDEX France

Tél : +3 (0)3.20.10.59.59 - Fax : +33 (0)3.20.35.57.22

Site : [www.solaronics.com](http://www.solaronics.com)

TECHNICAL INSTRUCTIONS GAS RADIANT TUBE SOLARHP L – NT15004E-GB – 10/11/2016

(repeat for multiple segments, if applicable)	..						
<b>Auxiliary electricity consumption</b>				<b>Heat output control type ( select one)</b>			
At nominal heat output	el max	0,058	kW	Single stage	no		
At minimum heat output	el min	0,058	kW	Two stage	yes		
In standby mode	el SB	(N.A)	kW	Modulating	no		
<b>Permanent pilot flame power requirement</b>							
Pilot flame power requirement (if applicable)	P pilot	(N.A)	kW				
Contact details	SOLARONICS Chauffage SA. 78 rue du Kimmel - B.P. 30173 – 59428 ARMENTIERES CEDEX France						
(*) NOx = nitrogen oxides							



SOLARONICS Chauffage SA. 78 rue du Kimmel – CS20302 – 59429 ARMENTIERES CEDEX France

Tél : +3 (0)3.20.10.59.59 - Fax : +33 (0)3.20.35.57.22

Site : [www.solaronics.com](http://www.solaronics.com)

TECHNICAL INSTRUCTIONS GAS RADIANT TUBE SOLARHP L – NT15004E-GB – 10/11/2016

Model identifier : <b>SolarHPL 36</b>							
Type of heating : <b>Radiant tube</b>							
<b>Fuel</b>		<b>Fuel</b>		Space heating emissions(*)			
				NOx			
Select fuel type		<b>Gaseous</b>		<b>G20/G25 /G31</b>		<b>132 mg/kWh input(GCV)</b>	
<b>Characteristics when operating with the preferred fuel only</b>							
Item	Symbol	Value	Unit	Item	Symbol	Value	Unit
<b>Heat output</b>				<b>Useful efficiency (GCV) – Tube local space heaters only</b>			
Nominal heat output	P <sub>nom</sub>	28,9	kW	Useful efficiency (GCV) at nominal heat output	$\eta_{th, nom}$	81,4	%
Minimum heat output	P <sub>min</sub>	(N.A)	kW	Useful efficiency at minimum heat output	$\eta_{th, min}$	(N.A)	%
Minimum heat output ( as percentage of nominal heat output)	..	(N.A)	%				
Nominal tube system heat output ( if applicable)	P système	(N.A)	kW				
Nominal tube segment heat output (if applicable)	P heater	(N.A)	kW	Useful efficiency of tube segment at minimum heat output ( if applicable)	$\eta_i$	(N.A)	%
(Repeat for multiple segment, if applicable)	..	(N.A)	kW	(repeat for multiple segments, if applicable)	..	(N.A)	%
Number of identical tube segments	n	(N.A)	(-)				
<b>Radiant factor</b>				<b>Envelope losses</b>			
Radiant factor at nominal heat output	RF <sub>nom</sub>	58,7	(-)	Envelope insulation class	U	(N.A)	W/ (m²K)
Radiant factor at minimum heat output	RF <sub>min</sub>	(N.A)	(-)	Envelope loss factor	F <sub>env</sub>	(N.A)	%
Radiant factor of tube segment at nominal heat output	RF <sub>i</sub>	(N.A)	(-)	Heat generator to be installed outside the heated area		No	



SOLARONICS Chauffage SA. 78 rue du Kimmel – CS20302 – 59429 ARMENTIERES CEDEX France

Tél : +3 (0)3.20.10.59.59 - Fax : +33 (0)3.20.35.57.22

Site : [www.solaronics.com](http://www.solaronics.com)

TECHNICAL INSTRUCTIONS GAS RADIANT TUBE SOLARHP L – NT15004E-GB – 10/11/2016

(repeat for multiple segments, if applicable)	..						
<b>Auxiliary electricity consumption</b>				<b>Heat output control type ( select one)</b>			
At nominal heat output	el max	0,138	kW	Single stage	yes		
At minimum heat output	el min	0,138	kW	Two stage	no		
In standby mode	el SB	(N.A)	kW	Modulating	no		
<b>Permanent pilot flame power requirement</b>							
Pilot flame power requirement (if applicable)	P pilot	(N.A)	kW				
Contact details	SOLARONICS Chauffage SA. 78 rue du Kimmel - B.P. 30173 – 59428 ARMENTIERES CEDEX France						
(*) NOx = nitrogen oxides							



SOLARONICS Chauffage SA. 78 rue du Kimmel – CS20302 – 59429 ARMENTIERES CEDEX France

Tél : +3 (0)3.20.10.59.59 - Fax : +33 (0)3.20.35.57.22

Site : [www.solaronics.com](http://www.solaronics.com)

TECHNICAL INSTRUCTIONS GAS RADIANT TUBE SOLARHP L – NT15004E-GB – 10/11/2016



Model identifier : <b>SolarHPL 36 2 stages</b>							
Type of heating : <b>Radiant tube</b>							
<b>Fuel</b>		<b>Fuel</b>		Space heating emissions(*)			
				NOx			
Select fuel type		<b>Gaseous</b>		<b>G20/G25 /G31</b>		<b>132 mg/kWh input(GCV)</b>	
<b>Characteristics when operating with the preferred fuel only</b>							
Item	Symbol	Value	Unit	Item	Symbol	Value	Unit
<b>Heat output</b>				<b>Useful efficiency (GCV) – Tube local space heaters only</b>			
Nominal heat output	P <sub>nom</sub>	28,9	kW	Useful efficiency (GCV) at nominal heat output	$\eta_{th, nom}$	81,4	%
Minimum heat output	P <sub>min</sub>	22,5	kW	Useful efficiency (GCV) at minimum heat output	$\eta_{th, min}$	79,5	%
Minimum heat output ( as percentage of nominal heat output)	..	77,9	%				
Nominal tube system heat output ( if applicable)	P système	(N.A)	kW				
Nominal tube segment heat output (if applicable)	P heater	(N.A)	kW	Useful efficiency of tube segment at minimum heat output ( if applicable)	$\eta_i$	(N.A)	%
(Repeat for multiple segment, if applicable)	..	(N.A)	kW	(repeat for multiple segments, if applicable)	..	(N.A)	%
Number of identical tube segments	n	(N.A)	(-)				
<b>Radiant factor</b>				<b>Envelope losses</b>			
Radiant factor at nominal heat output	RF <sub>nom</sub>	58,7	(-)	Envelope insulation class	U	(N.A)	W/ (m²K)
Radiant factor at minimum heat output	RF <sub>min</sub>	58,7	(-)	Envelope loss factor	F <sub>env</sub>	(N.A)	%
Radiant factor of tube segment at nominal heat output	RF <sub>i</sub>	(N.A)	(-)	Heat generator to be installed outside the heated area		No	



SOLARONICS Chauffage SA. 78 rue du Kimmel – CS20302 – 59429 ARMENTIERES CEDEX France  
Tél : +3 (0)3.20.10.59.59 - Fax : +33 (0)3.20.35.57.22  
Site : [www.solaronics.com](http://www.solaronics.com)

TECHNICAL INSTRUCTIONS GAS RADIANT TUBE SOLARHP L – NT15004E-GB – 10/11/2016

(repeat for multiple segments, if applicable)	..						
<b>Auxiliary electricity consumption</b>				<b>Heat output control type ( select one)</b>			
At nominal heat output	el max	0,138	kW	Single stage	no		
At minimum heat output	el min	0,138	kW	Two stage	yes		
In standby mode	el SB	(N.A)	kW	Modulating	no		
<b>Permanent pilot flame power requirement</b>							
Pilot flame power requirement (if applicable)	P pilot	(N.A)	kW				
Contact details	SOLARONICS Chauffage SA. 78 rue du Kimmel - B.P. 30173 – 59428 ARMENTIERES CEDEX France						
(*) NOx = nitrogen oxides							



SOLARONICS Chauffage SA. 78 rue du Kimmel – CS20302 – 59429 ARMENTIERES CEDEX France

Tél : +3 (0)3.20.10.59.59 - Fax : +33 (0)3.20.35.57.22

Site : [www.solaronics.com](http://www.solaronics.com)

TECHNICAL INSTRUCTIONS GAS RADIANT TUBE SOLARHP L – NT15004E-GB – 10/11/2016

Model identifier : <b>SolarHPL 50</b>							
Type of heating : <b>Radiant tube</b>							
<b>Fuel</b>		<b>Fuel</b>		Space heating emissions(*)			
				NOx			
Select fuel type		<b>Gaseous</b>		<b>G20/G25 /G31</b>		<b>157 mg/kWh input(GCV)</b>	
<b>Characteristics when operating with the preferred fuel only</b>							
Item	Symbol	Value	Unit	Item	Symbol	Value	Unit
<b>Heat output</b>				<b>Useful efficiency (GCV) – Tube local space heaters only</b>			
Nominal heat output	P <sub>nom</sub>	43,7	kW	Useful efficiency (GCV) at nominal heat output	$\eta_{th, nom}$	82,1	%
Minimum heat output	P <sub>min</sub>	(N.A)	kW	Useful efficiency at minimum heat output	$\eta_{th, min}$	(N.A)	%
Minimum heat output ( as percentage of nominal heat output)	..	(N.A)	%				
Nominal tube system heat output ( if applicable)	P système	(N.A)	kW				
Nominal tube segment heat output (if applicable)	P heater	(N.A)	kW	Useful efficiency of tube segment at minimum heat output ( if applicable)	$\eta_i$	(N.A)	%
(Repeat for multiple segment, if applicable)	..	(N.A)	kW	(repeat for multiple segments, if applicable)	..	(N.A)	%
Number of identical tube segments	n	(N.A)	(-)				
<b>Radiant factor</b>				<b>Envelope losses</b>			
Radiant factor at nominal heat output	RF <sub>nom</sub>	59,2	(-)	Envelope insulation class	U	(N.A)	W/ (m²K)
Radiant factor at minimum heat output	RF <sub>min</sub>	(N.A)	(-)	Envelope loss factor	F <sub>env</sub>	(N.A)	%
Radiant factor of tube segment at nominal heat output	RF <sub>i</sub>	(N.A)	(-)	Heat generator to be installed outside the heated area		No	



SOLARONICS Chauffage SA. 78 rue du Kimmel – CS20302 – 59429 ARMENTIERES CEDEX France  
Tél : +3 (0)3.20.10.59.59 - Fax : +33 (0)3.20.35.57.22  
Site : [www.solaronics.com](http://www.solaronics.com)

TECHNICAL INSTRUCTIONS GAS RADIANT TUBE SOLARHP L – NT15004E-GB – 10/11/2016

(repeat for multiple segments, if applicable)	..						
<b>Auxiliary electricity consumption</b>				<b>Heat output control type ( select one)</b>			
At nominal heat output	el max	0,230	kW	Single stage	yes		
At minimum heat output	el min	0,230	kW	Two stage	no		
In standby mode	el SB	(N.A)	kW	Modulating	no		
<b>Permanent pilot flame power requirement</b>							
Pilot flame power requirement (if applicable)	P pilot	(N.A)	kW				
Contact details	SOLARONICS Chauffage SA. 78 rue du Kimmel - B.P. 30173 – 59428 ARMENTIERES CEDEX France						
(*) NOx = nitrogen oxides							



SOLARONICS Chauffage SA. 78 rue du Kimmel – CS20302 – 59429 ARMENTIERES CEDEX France

Tél : +3 (0)3.20.10.59.59 - Fax : +33 (0)3.20.35.57.22

Site : [www.solaronics.com](http://www.solaronics.com)

TECHNICAL INSTRUCTIONS GAS RADIANT TUBE SOLARHP L – NT15004E-GB – 10/11/2016

Model identifier : <b>SolarHPL 50 2 stages</b>							
Type of heating : <b>Radiant tube</b>							
<b>Fuel</b>		<b>Fuel</b>		Space heating emissions(*)			
				NOx			
Select fuel type		<b>Gaseous</b>		<b>G20/G25 /G31</b>		<b>157 mg/kWh input(GCV)</b>	
<b>Characteristics when operating with the preferred fuel only</b>							
Item	Symbol	Value	Unit	Item	Symbol	Value	Unit
<b>Heat output</b>				<b>Useful efficiency (GCV) – Tube local space heaters only</b>			
Nominal heat output	P <sub>nom</sub>	43,7	kW	Useful efficiency (GCV) at nominal heat output	$\eta_{th, nom}$	82,1	%
Minimum heat output	P <sub>min</sub>	33	kW	Useful efficiency (GCV) at minimum heat output	$\eta_{th, min}$	80,4	%
Minimum heat output ( as percentage of nominal heat output)	..	75,5	%				
Nominal tube system heat output ( if applicable)	P système	(N.A)	kW				
Nominal tube segment heat output (if applicable)	P heater	(N.A)	kW	Useful efficiency of tube segment at minimum heat output ( if applicable)	$\eta_i$	(N.A)	%
(Repeat for multiple segment, if applicable)	..	(N.A)	kW	(repeat for multiple segments, if applicable)	..	(N.A)	%
Number of identical tube segments	n	(N.A)	(-)				
<b>Radiant factor</b>				<b>Envelope losses</b>			
Radiant factor at nominal heat output	RF <sub>nom</sub>	59,2	(-)	Envelope insulation class	U	(N.A)	W/ (m²K)
Radiant factor at minimum heat output	RF <sub>min</sub>	59,2	(-)	Envelope loss factor	F <sub>env</sub>	(N.A)	%
Radiant factor of tube segment at nominal heat output	RF <sub>i</sub>	(N.A)	(-)	Heat generator to be installed outside the heated area		No	



SOLARONICS Chauffage SA. 78 rue du Kimmel – CS20302 – 59429 ARMENTIERES CEDEX France

Tél : +3 (0)3.20.10.59.59 - Fax : +33 (0)3.20.35.57.22

Site : [www.solaronics.com](http://www.solaronics.com)

TECHNICAL INSTRUCTIONS GAS RADIANT TUBE SOLARHP L – NT15004E-GB – 10/11/2016

(repeat for multiple segments, if applicable)	..						
<b>Auxiliary electricity consumption</b>				<b>Heat output control type ( select one)</b>			
At nominal heat output	el max	0,230	kW	Single stage	no		
At minimum heat output	el min	0,230	kW	Two stage	yes		
In standby mode	el SB	(N.A)	kW	Modulating	no		
<b>Permanent pilot flame power requirement</b>							
Pilot flame power requirement (if applicable)	P pilot	(N.A)	kW				
Contact details	SOLARONICS Chauffage SA. 78 rue du Kimmel - B.P. 30173 – 59428 ARMENTIERES CEDEX France						
(*) NOx = nitrogen oxides							



SOLARONICS Chauffage SA. 78 rue du Kimmel – CS20302 – 59429 ARMENTIERES CEDEX France

Tél : +3 (0)3.20.10.59.59 - Fax : +33 (0)3.20.35.57.22

Site : [www.solaronics.com](http://www.solaronics.com)

TECHNICAL INSTRUCTIONS GAS RADIANT TUBE SOLARHP L – NT15004E-GB – 10/11/2016

## APPENDIX

### End of life of equipment

This device contains electrical and / or electronic components and should not be considered as household waste. Ensure compliance with applicable standards and regulations for waste disposal when dismantling.

### The right thing for the safety

Keep ventilation in good condition:

- Keep free and clear air inlets and outlets (grids, vents ...)
- Check annually flues ducts.

Maintain equipment:

- Maintain or make maintain the equipment by a competent person at appropriate intervals, following the manufacturer's recommendations
- Check the gas appliance by a competent person in case of triggering of a safety device

### Smell gas? Good reactions!

Flammable but non toxic, gas has been odorized to allow discovering any leak, even small. This smell allows you to react fast. If you smell gas, close the gas valve and check the equipment. If everything is normal and the smell persists, you have to have the good reflexes



#### WARNING

**DO NOT PROVOKE ANY FLAME OR SPARK ... AND DO NOT USE ELECTRICAL APPLIANCES**

- Do not call an elevator, use a phone, even mobile, press an electric switch, not to create a spark.
- Whatever the room where the gas smell is perceived, ventilate this room as much as possible by opening windows and doors...

"Gas troubleshooting" service is at your disposal 24/24 and 7/7 at the gas distributor. This service reacts free of charge and as soon as possible in case of gas leak or smell.

- The phone number is: ....., it is noted on the invoices

The number of the emergency services (fire) is: .....



SOLARONICS Chauffage SA. 78 rue du Kimmel – CS20302 – 59429 ARMENTIERES CEDEX France

Tél : +3 (0)3.20.10.59.59 - Fax : +33 (0)3.20.35.57.22

Site : [www.solaronics.com](http://www.solaronics.com)

TECHNICAL INSTRUCTIONS GAS RADIANT TUBE SOLARHP L – NT15004E-GB – 10/11/2016



Catalogue Tarif  
Professionnel



Pièces de rechange



Spare parts catalogue

On request

**Headquarters**

ZI N°3, 78 rue du Kimmel – CS20302  
59429 ARMENTIÈRES Cedex – FRANCE  
Phone. : +33 3 20 10 59 59  
Fax : +33 3 20 35 57 22

